

Color Management Concepts

ARNAB MAITI

Regional Manager – Prepress Solutions & Packaging Segment



Kodak



What is Color Management...

What is Management

What is Color

A Little Understanding for Color(1)...



A Little Understanding for Color(2)...

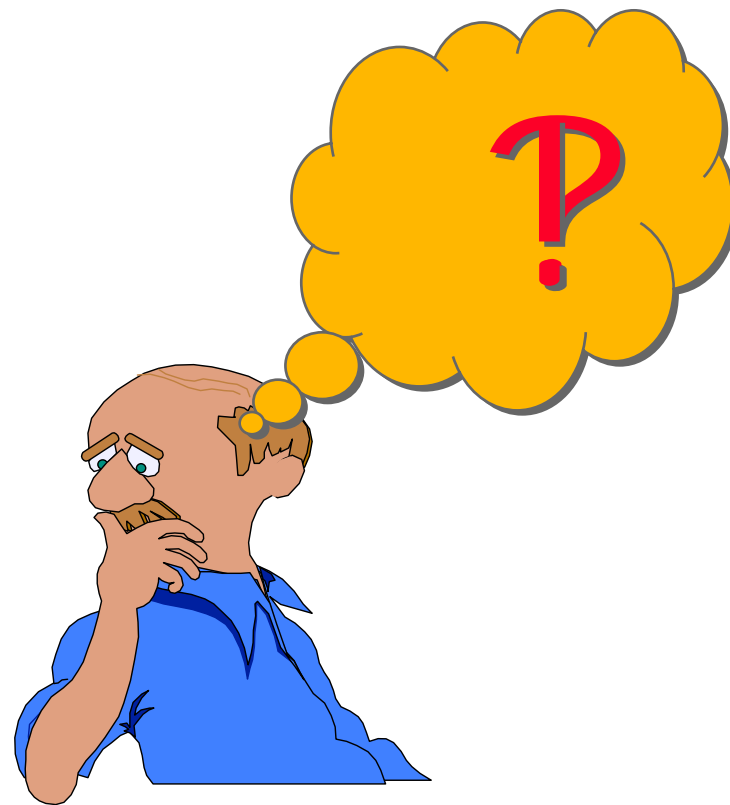
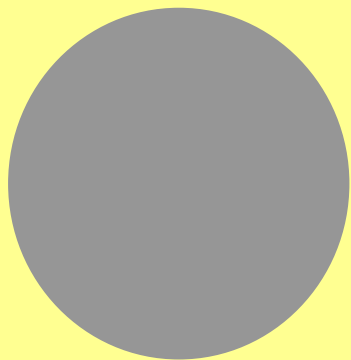

What is Color...

Color is Perception

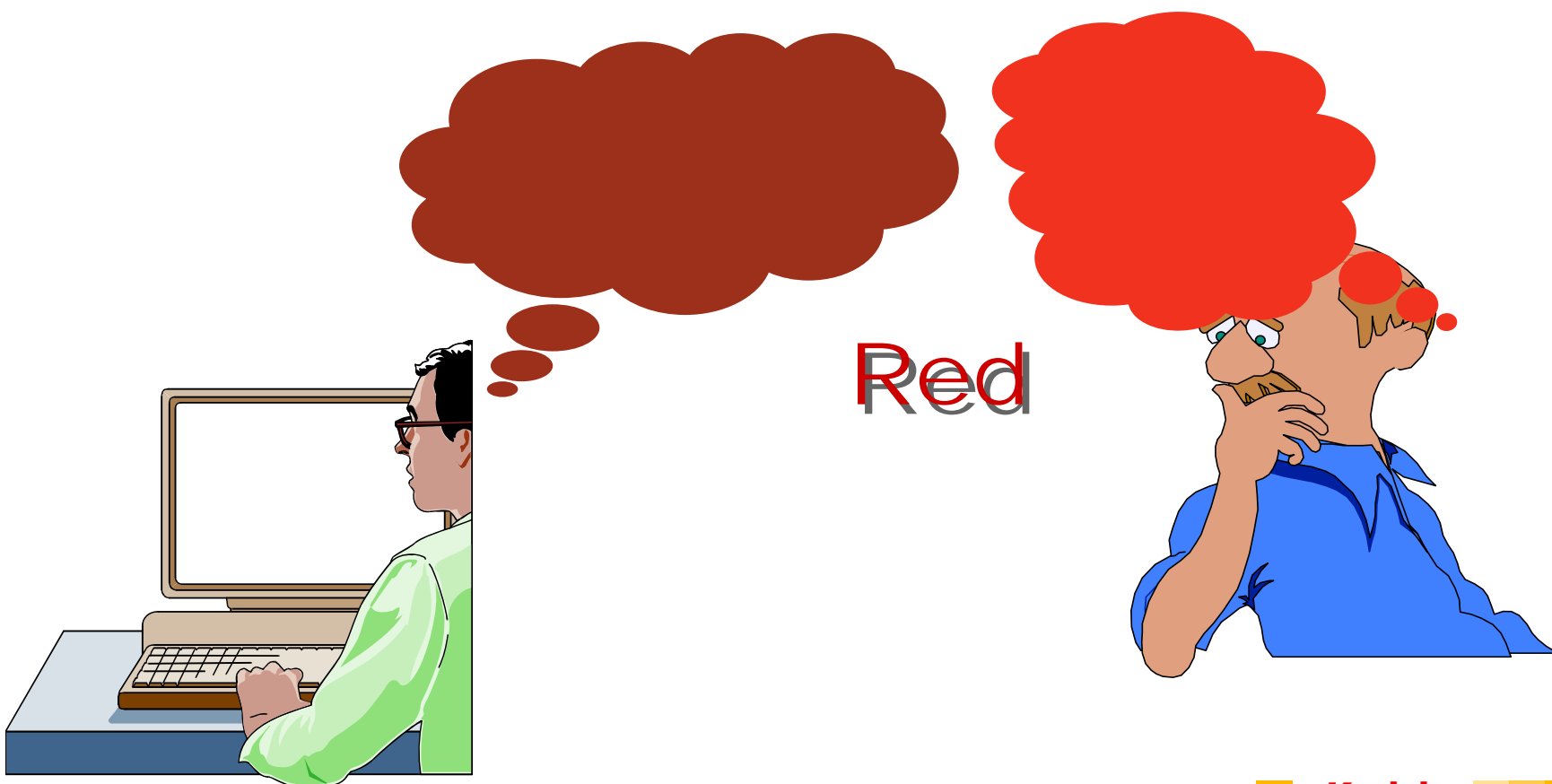

What is Color...

Color is perception

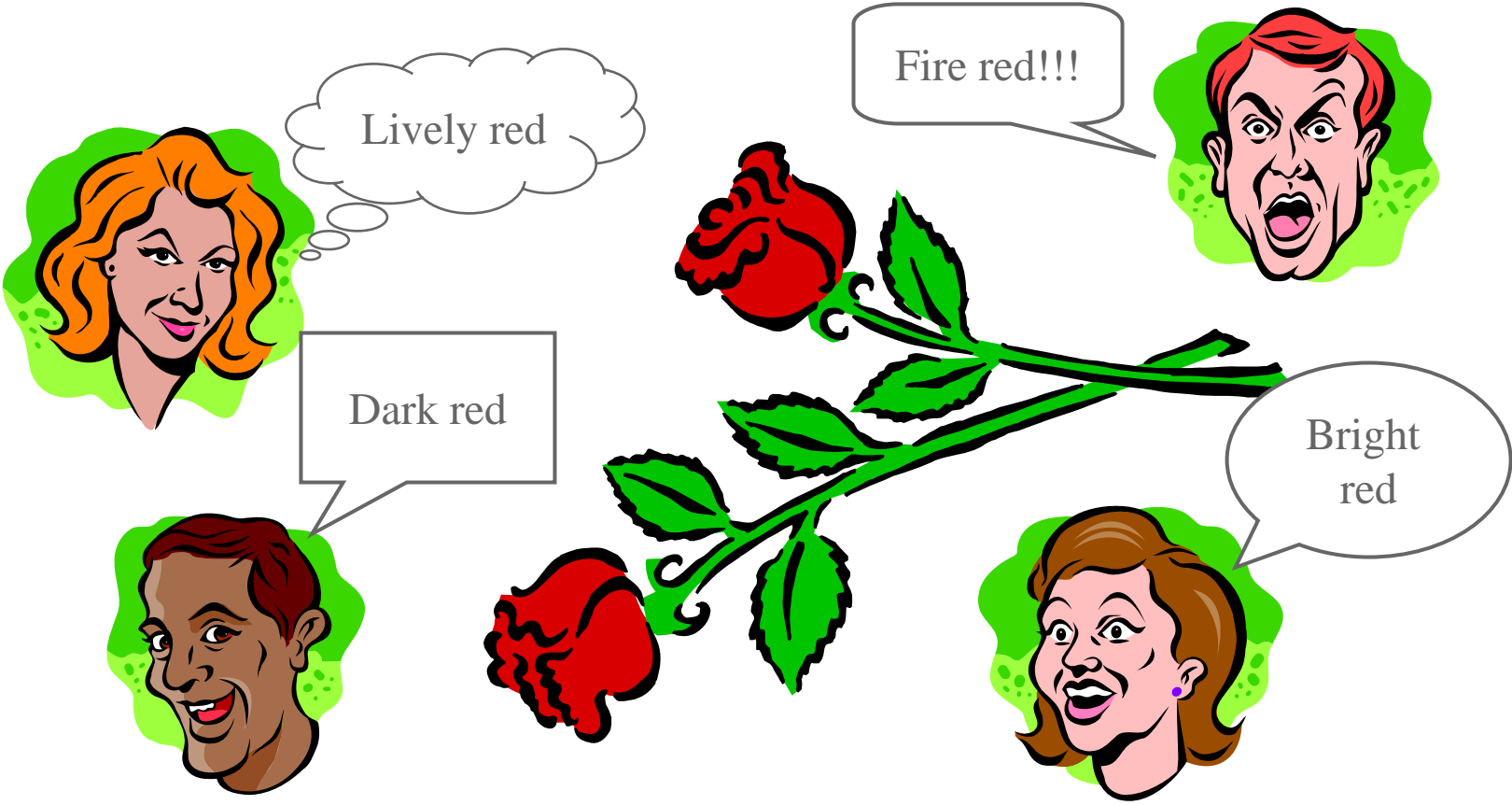

What is Color Management...

Color Management is managing
the feeling!



Because our feeling defines the Color!

Human Color perception: 3 stages

- **Retina :** **RGB**
- **Ganglion:** opponent colors red - green and blue - yellow (**CIELab**)
- **Cortex[brain]:** **LCH**

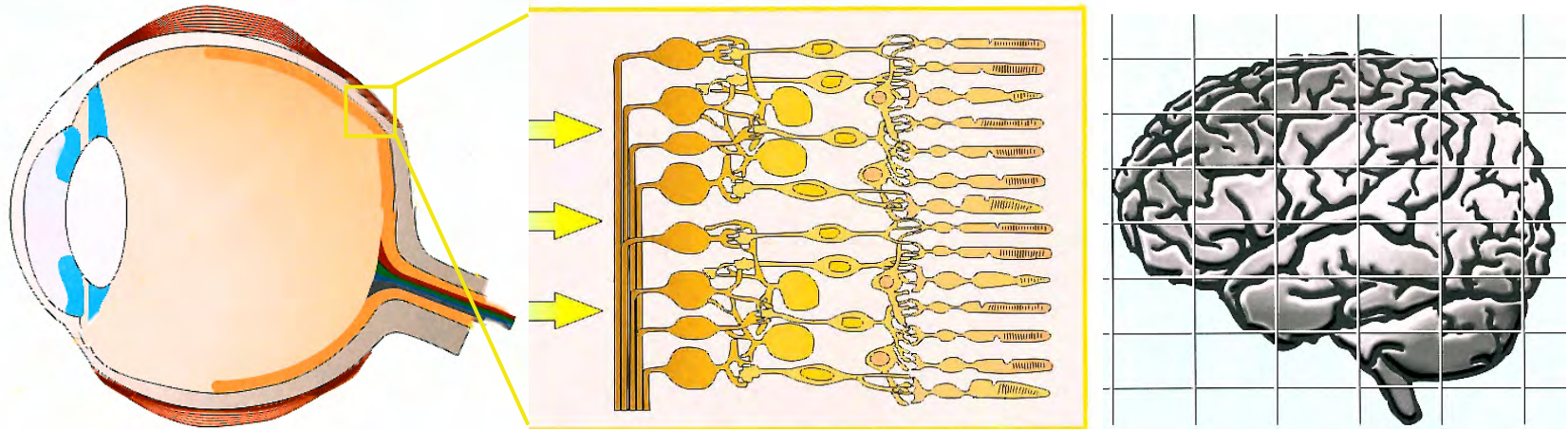

Color is a 3 dimensional Space...

RGB_{EBU}

RGB_{NTSC}

Lab

LCH

XYZ

YCC

Color Calculation...

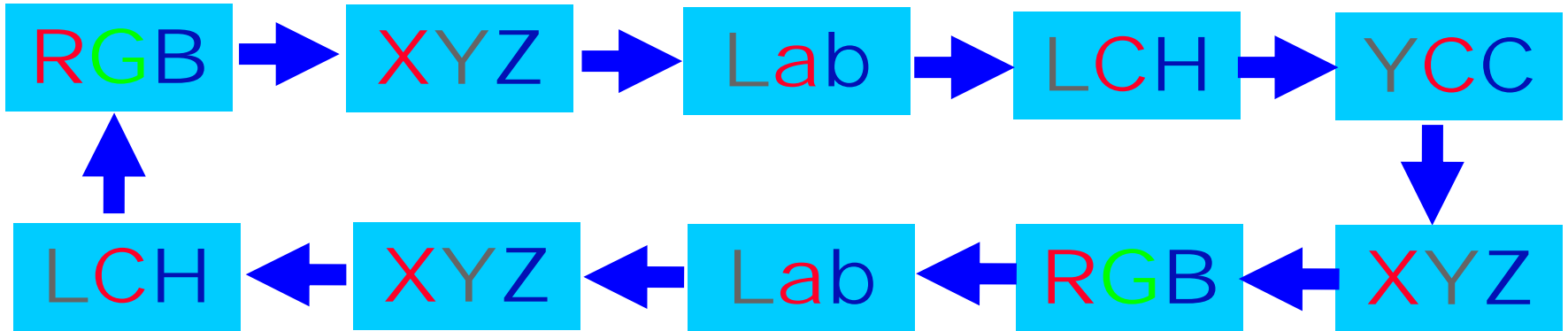

We can calculate Color from one 3 dimensional Color Space to another 3 dimensional Color Space **EXACTLY**

Reason for Color Management

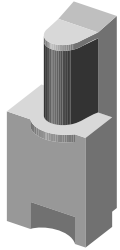

Scanner



Monitor

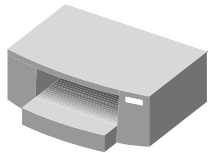

Proofer

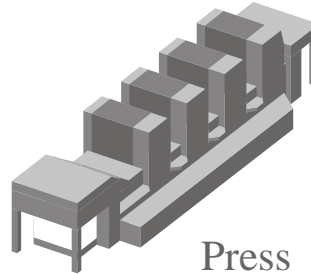

Press



- Every device sees color different
- They work in different color spaces

Every device has its own color gamut

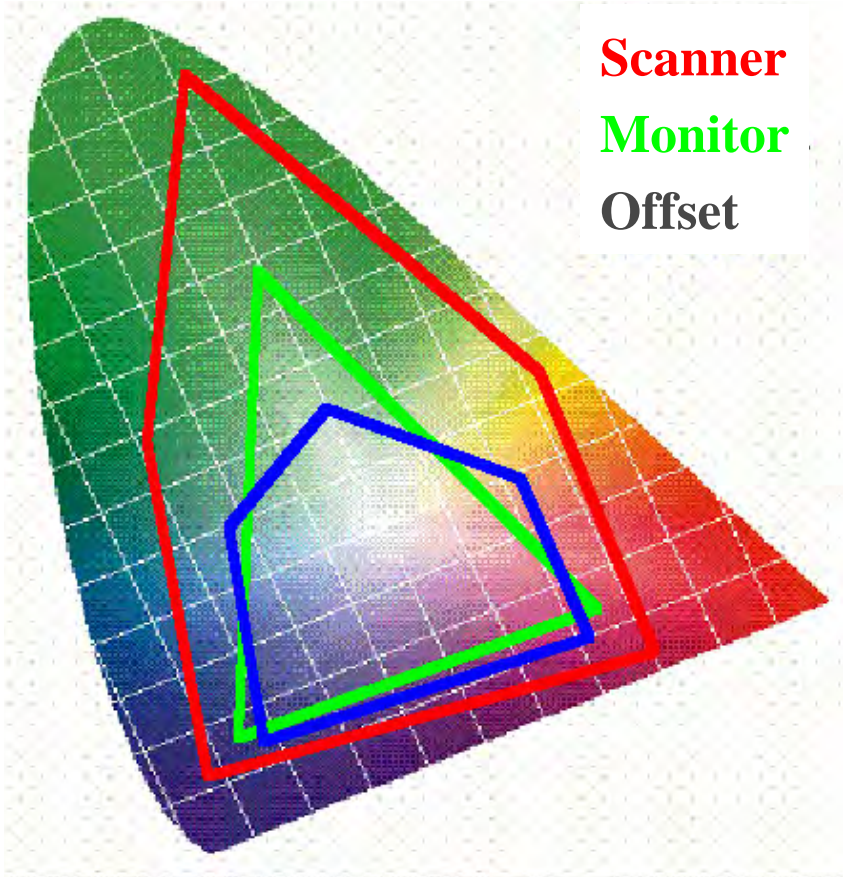

MAPPING OF COLOR SPACES

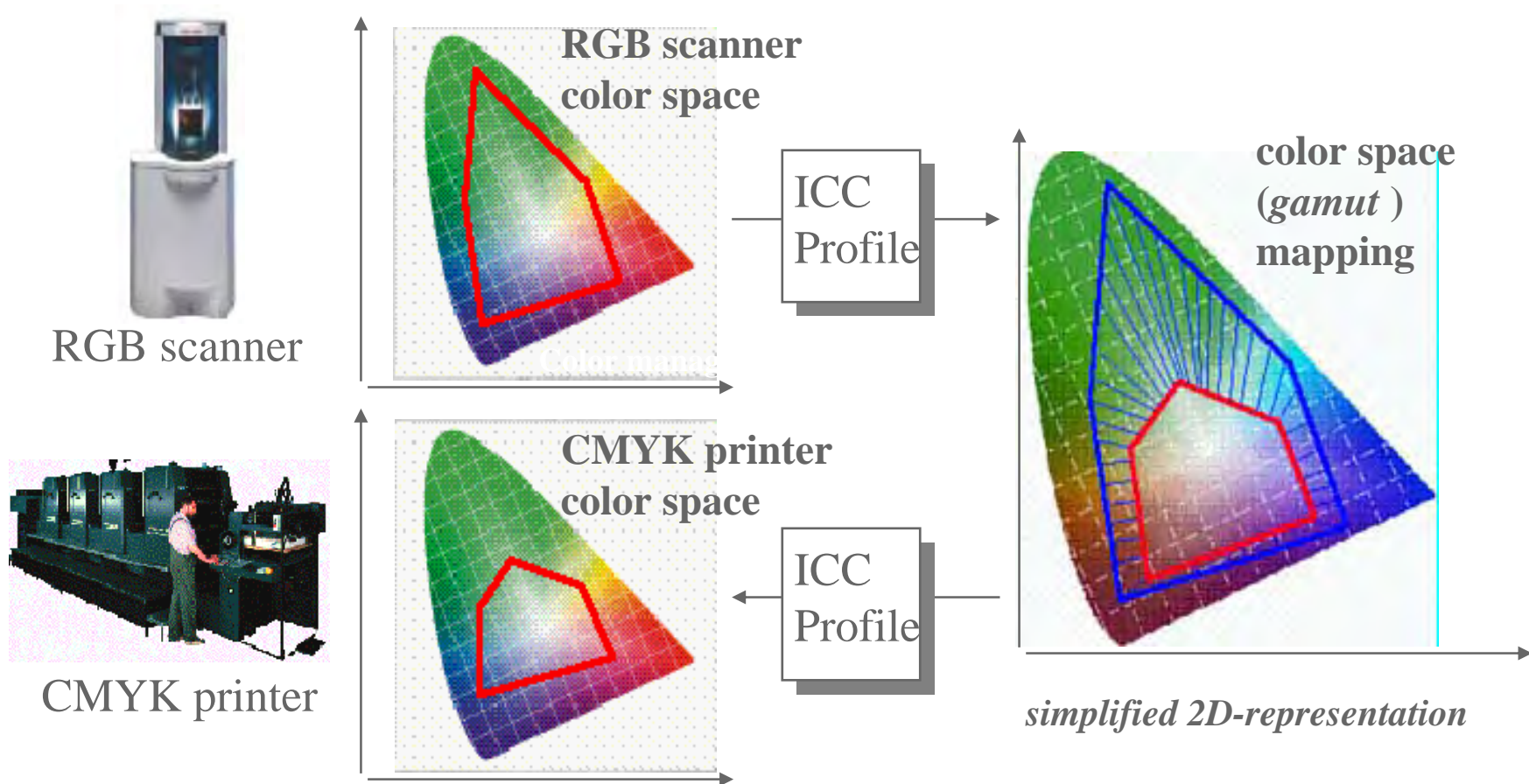

■ false colors, posterization or color shifts, if transformation not done properly

Color Publishing System...

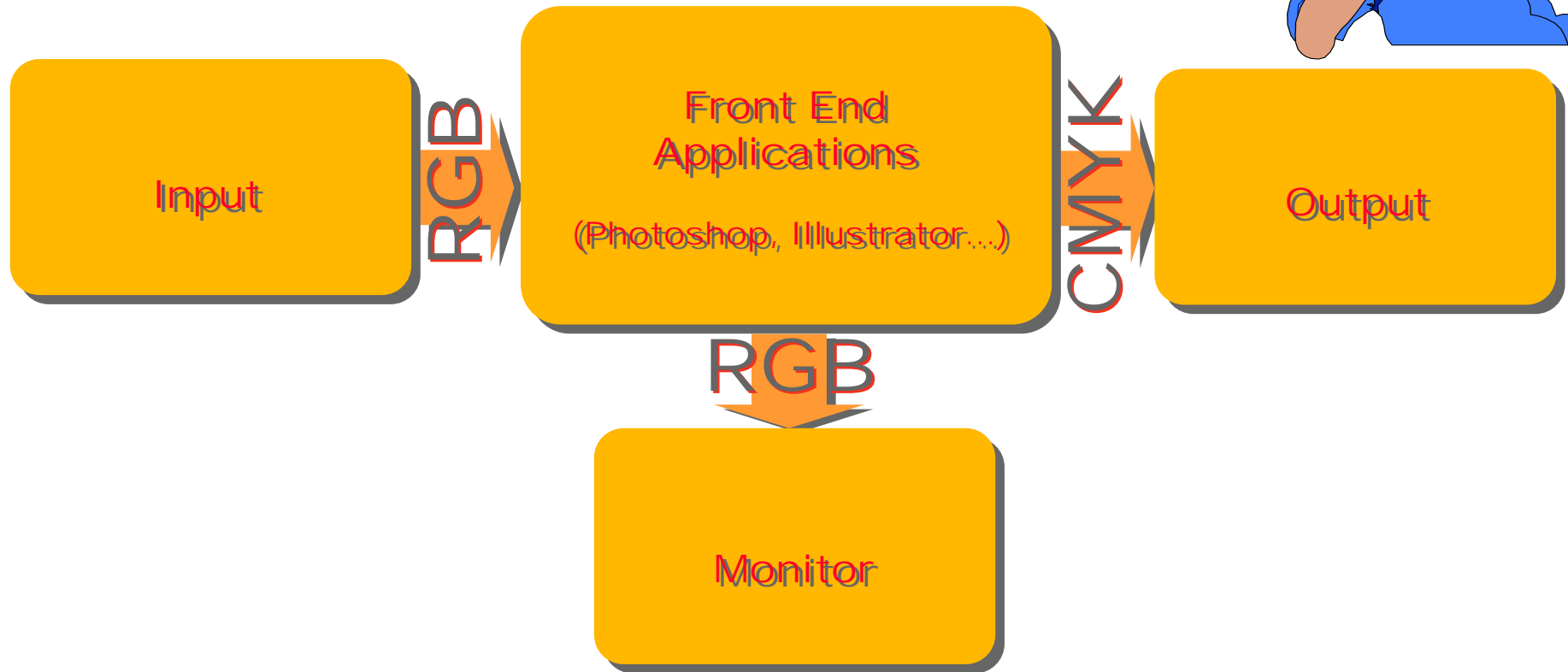

Color Publishing System...

Closed systems

- components from one vendor
- limited number of components
- proprietary interfaces
- skilled users
- CMM integrated and hidden

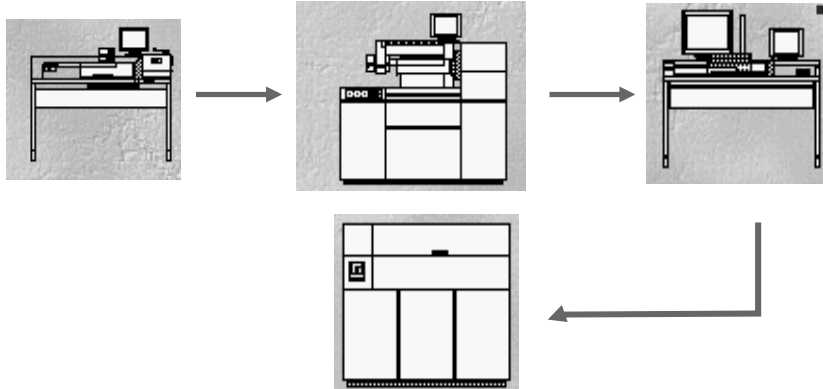

Good results!

Open systems: DTP

- components of different vendors
- unlimited number of components
- open interfaces
- users with limited knowhow
- CMM users responsibility

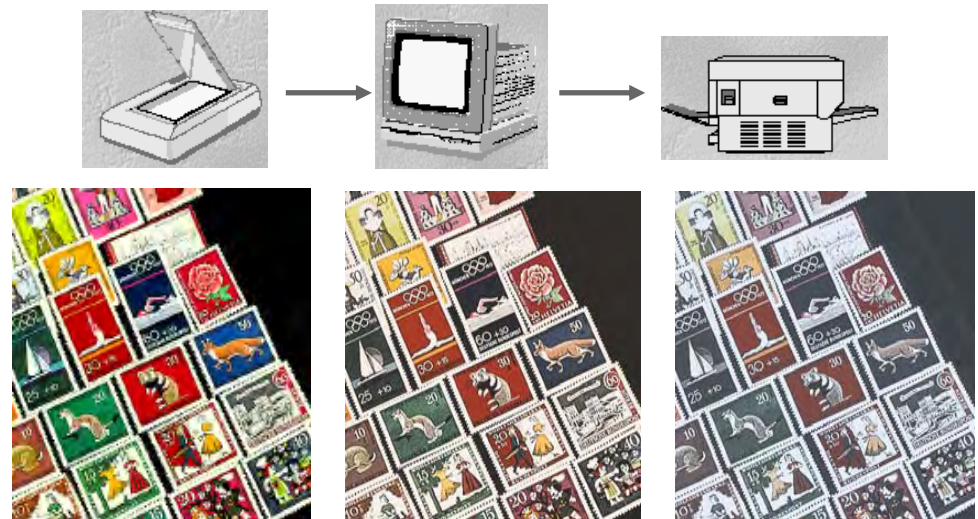

Unsatisfactory results!

Conventional Color Reproduction...

RGB₁

RGB₂

CMYK



Color?

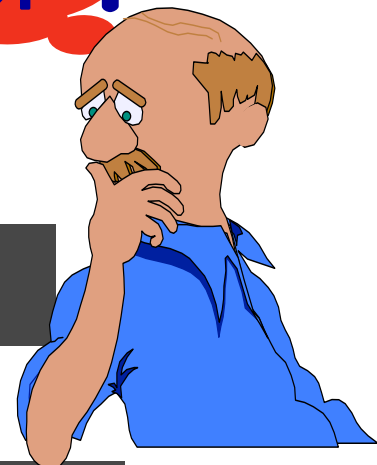

RGB

CMYK₁

CMYK₂

Equipment Management

And the real world...

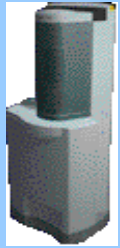
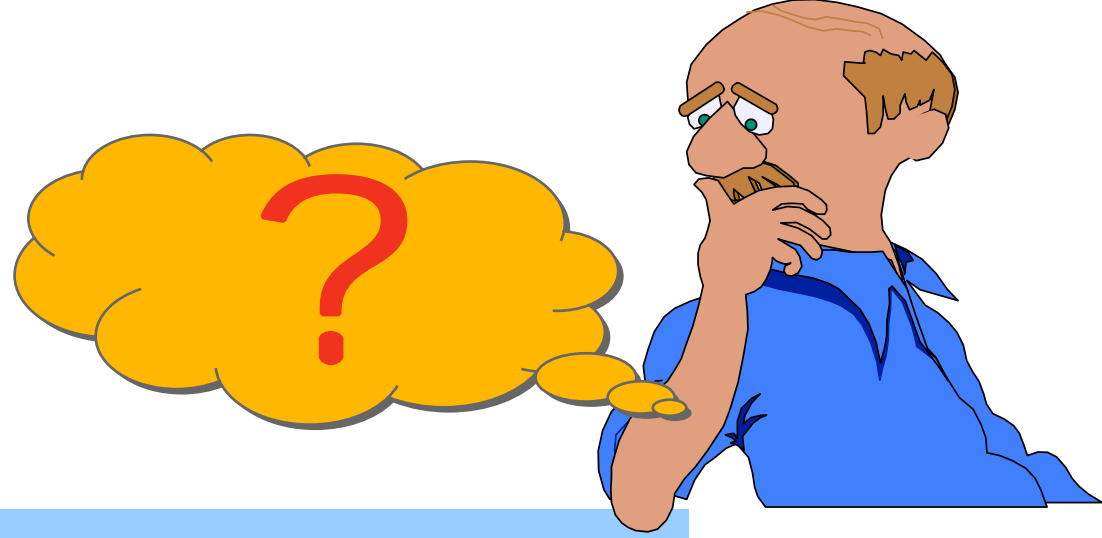

Scanner



Monitor



Proofer

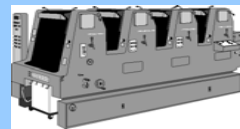

Press



3 Components of Color Management systems

CMM: Color Matching Method [color transformation]

Profiling - SW

Applications

Essential of Color Management...

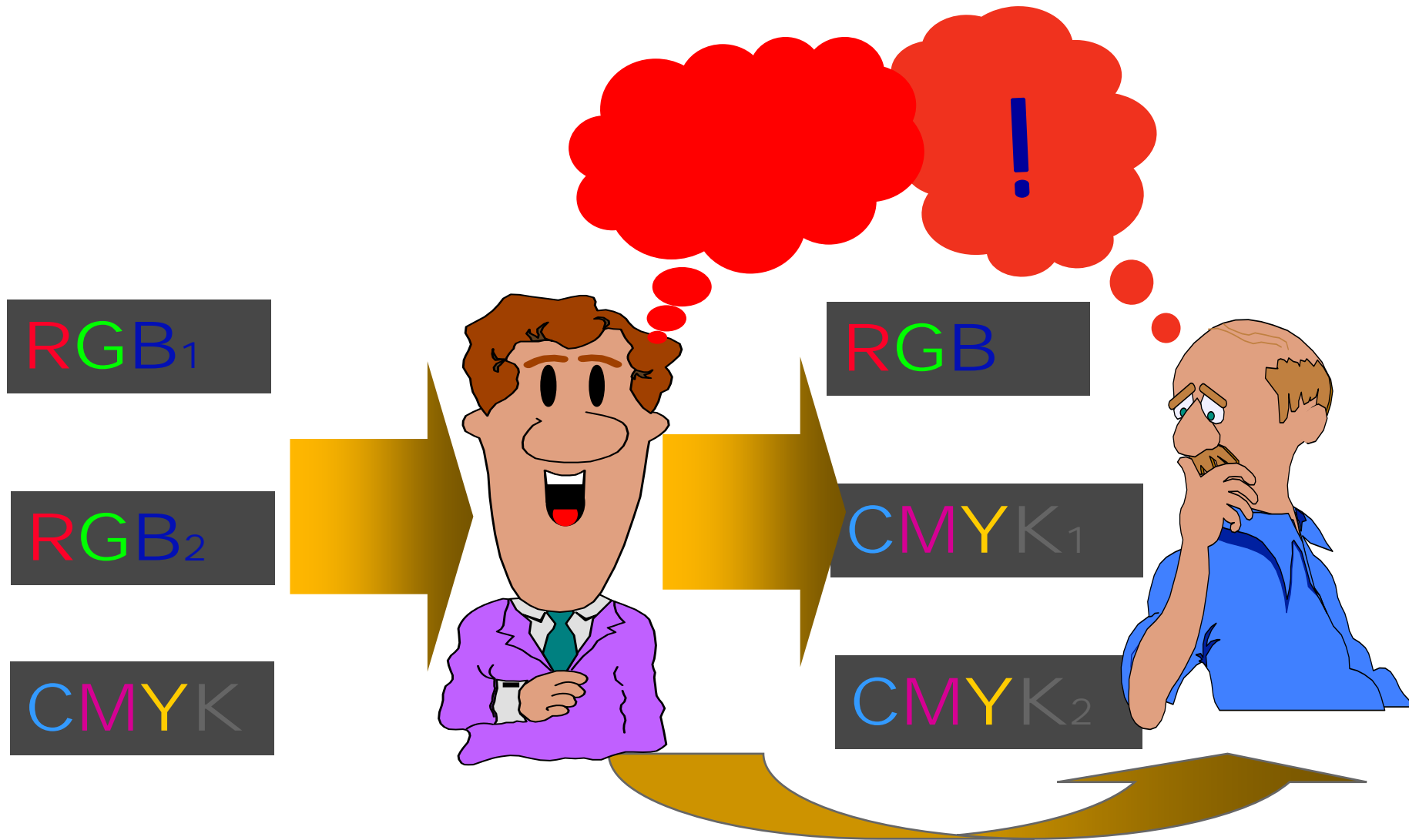

Scanning Methods

Scanning

- Whereas a digital camera creates a picture,
- a scanner reproduces an already existing one.
- Two technologies are available for this:
 - CCDs (charge coupled devices) for flatbed scanners, and
 - PMTs (photo multiplier tubes) for drum scanners

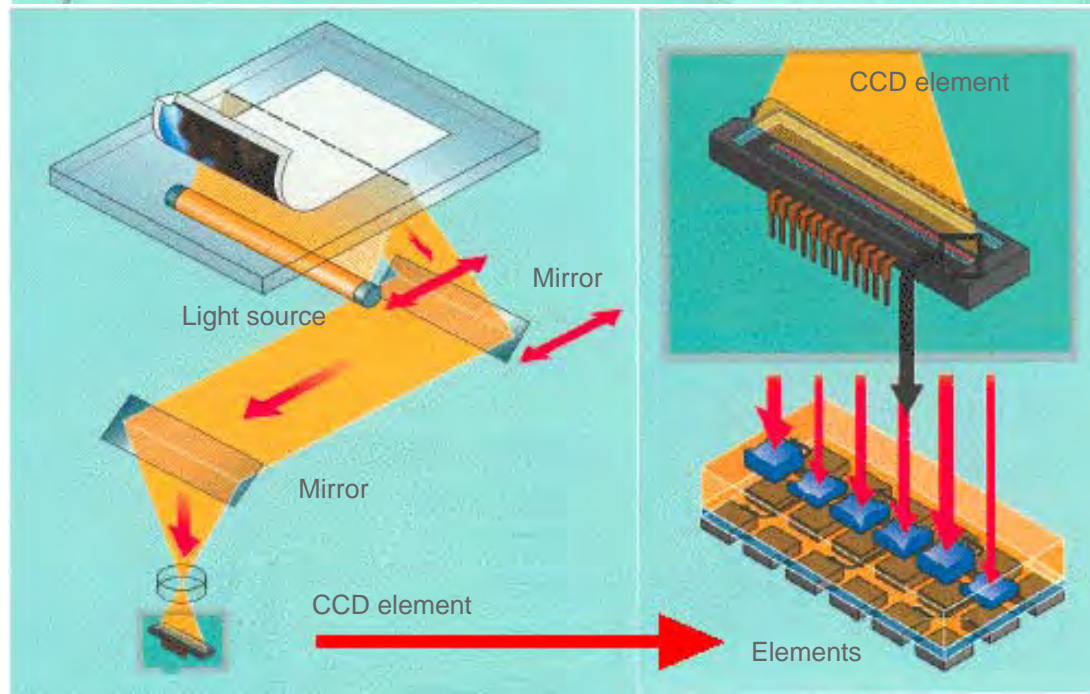
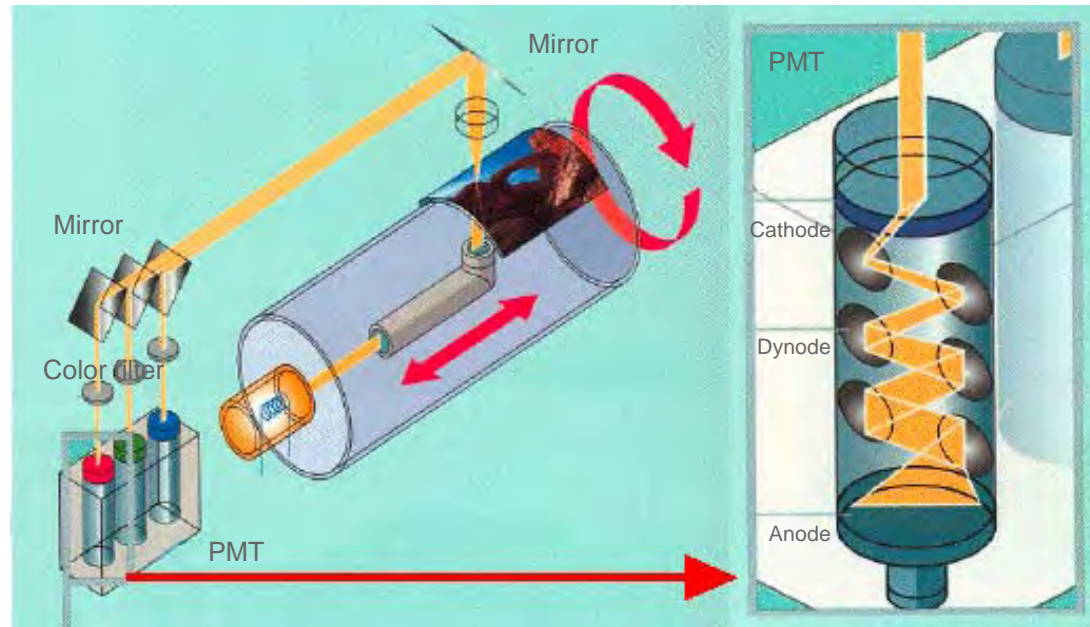

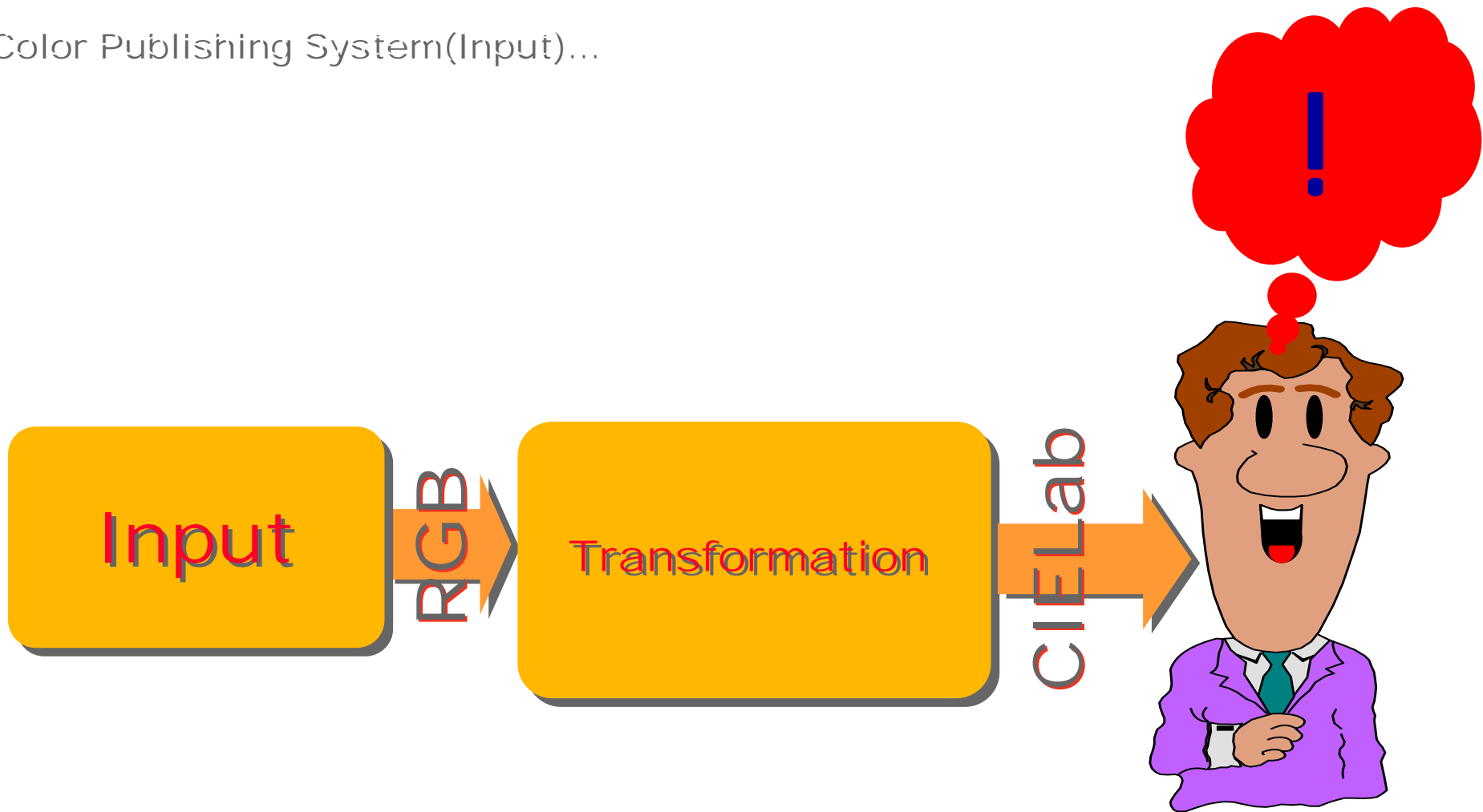

Input System should give the **COMPLETE** information of the Original

Color Publishing System(Output 1)...

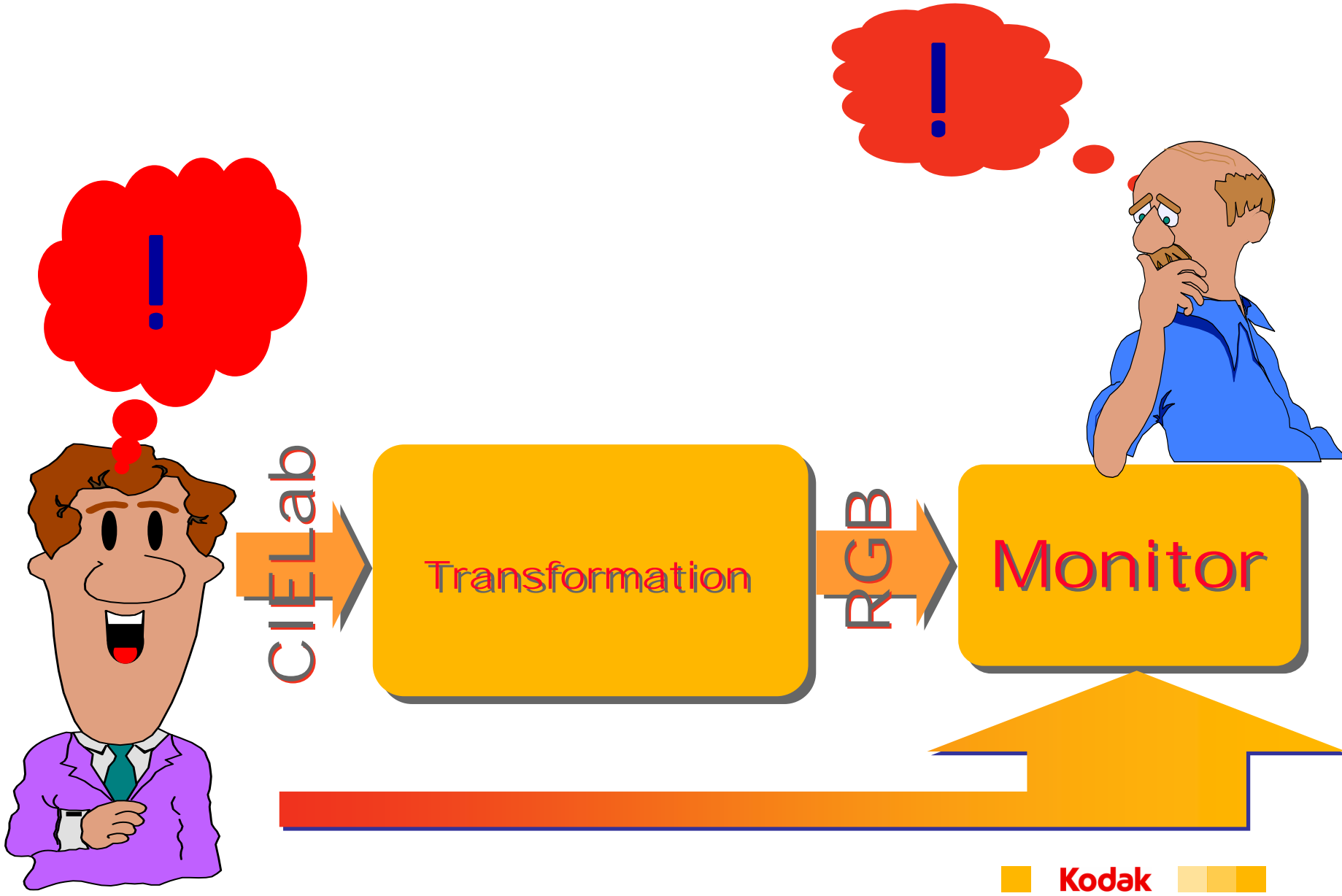

Color Publishing System(Output 2)...

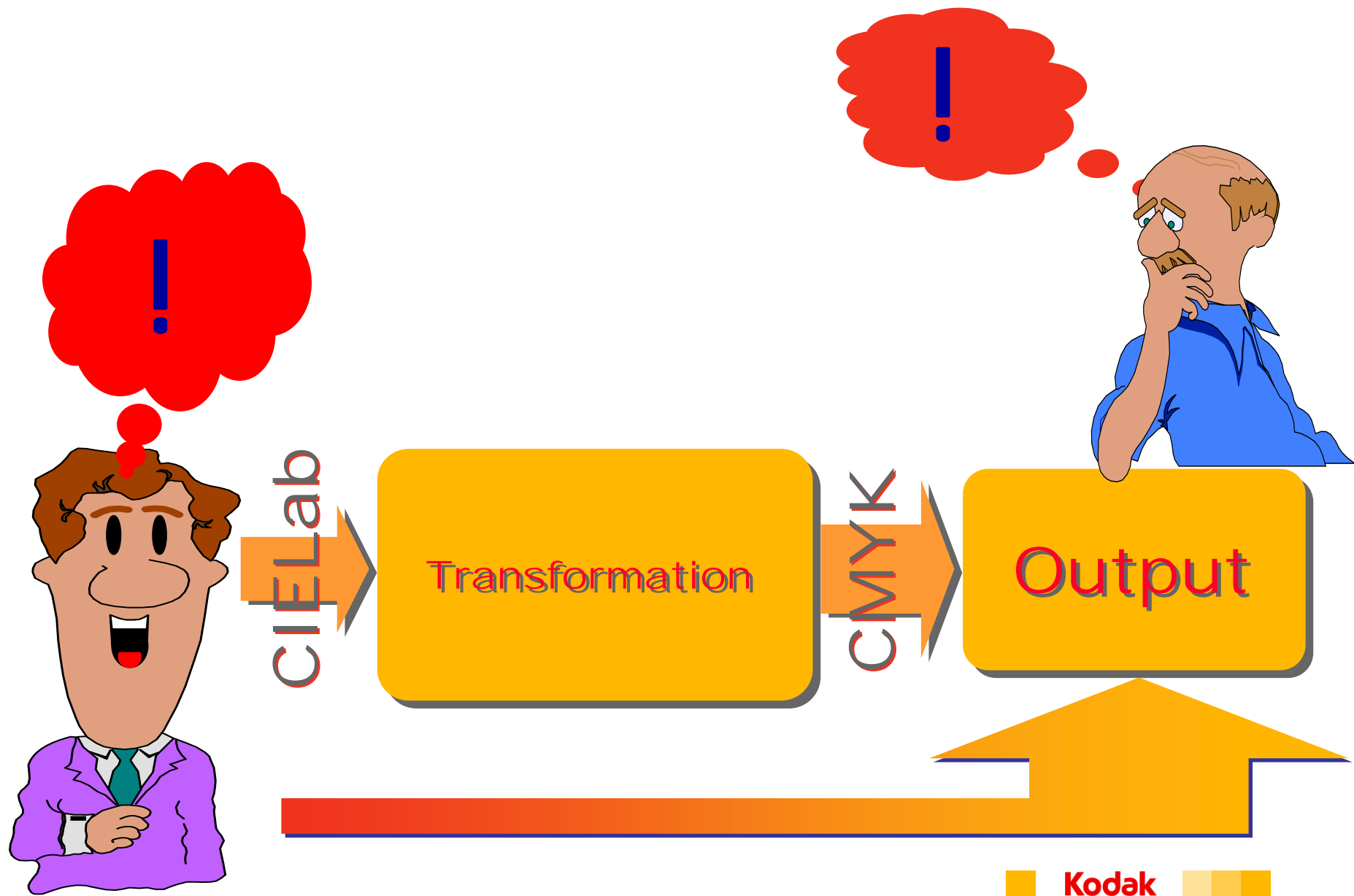

Components of Color Management

Color Management tools

- Needs of a Color Management system?
 - Color Matching Method for color transformation
 - Device - profiles for characterization
 - Applications

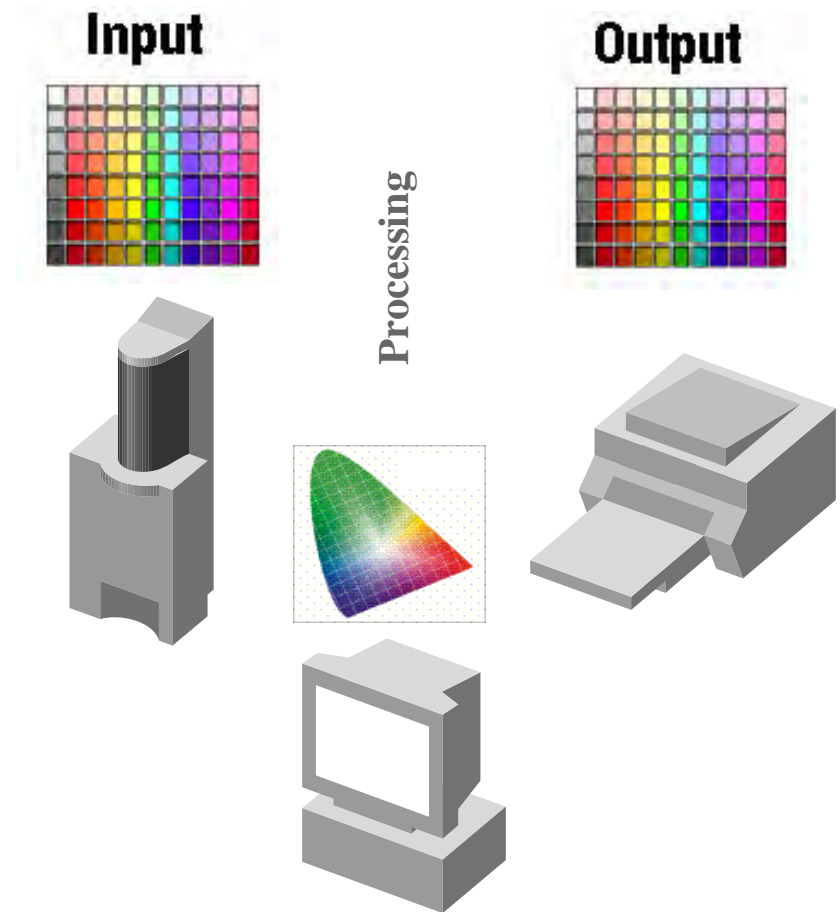

Color Matching Method

- Tasks:
 - makes color transformations
- Organisation:
 - Target: integrated in OS
 - Mac : in OS; ColorSync
 - PC :
 - Win 98, Win 2000: in OS
 - Win NT, Win 95: part of applications



Color Management – idea and principle:

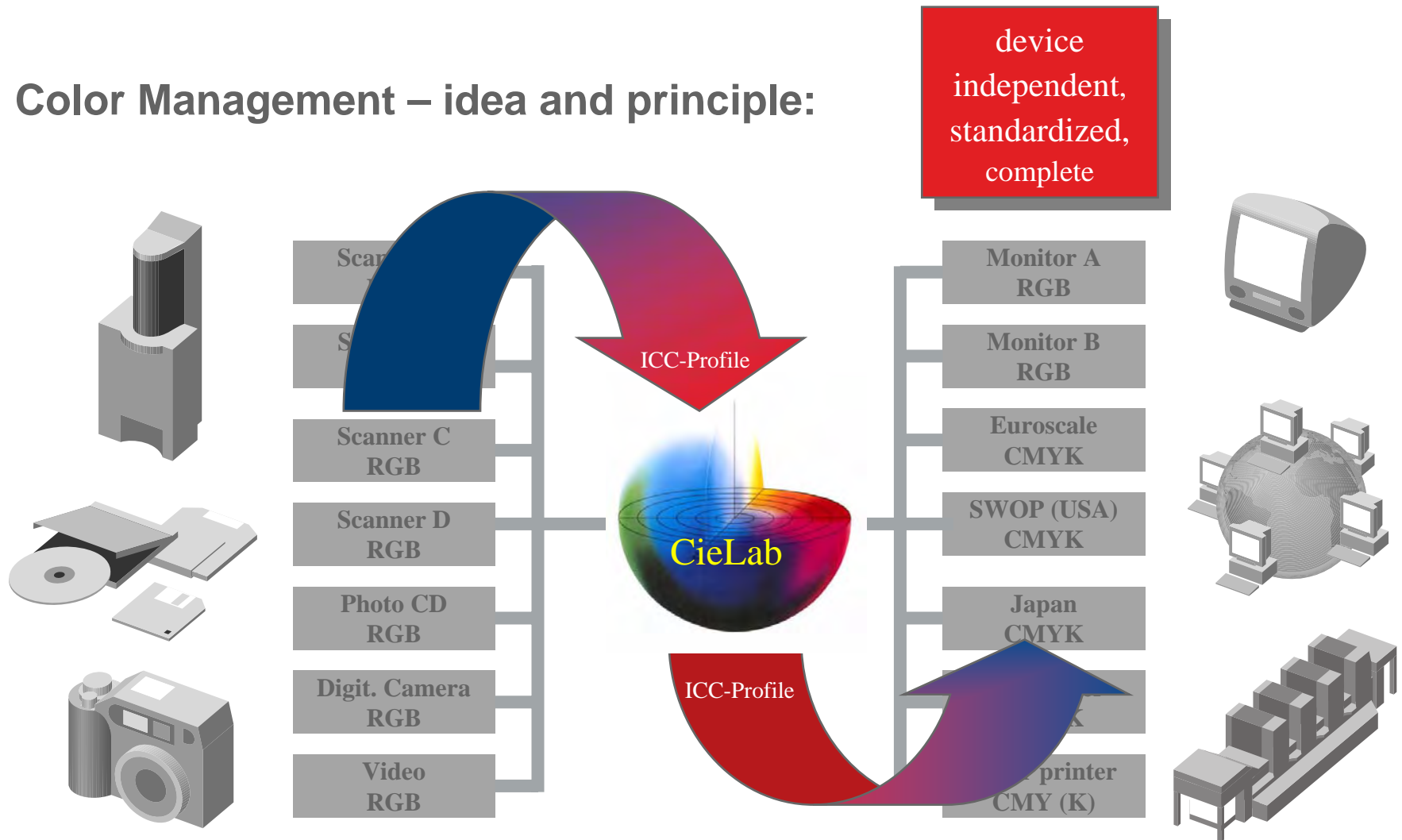

Profile connection space: CIE Lab

Color Publishing System with CM



Remember

 Color Management is only possible with a system based on CIE Lab (human feeling)!

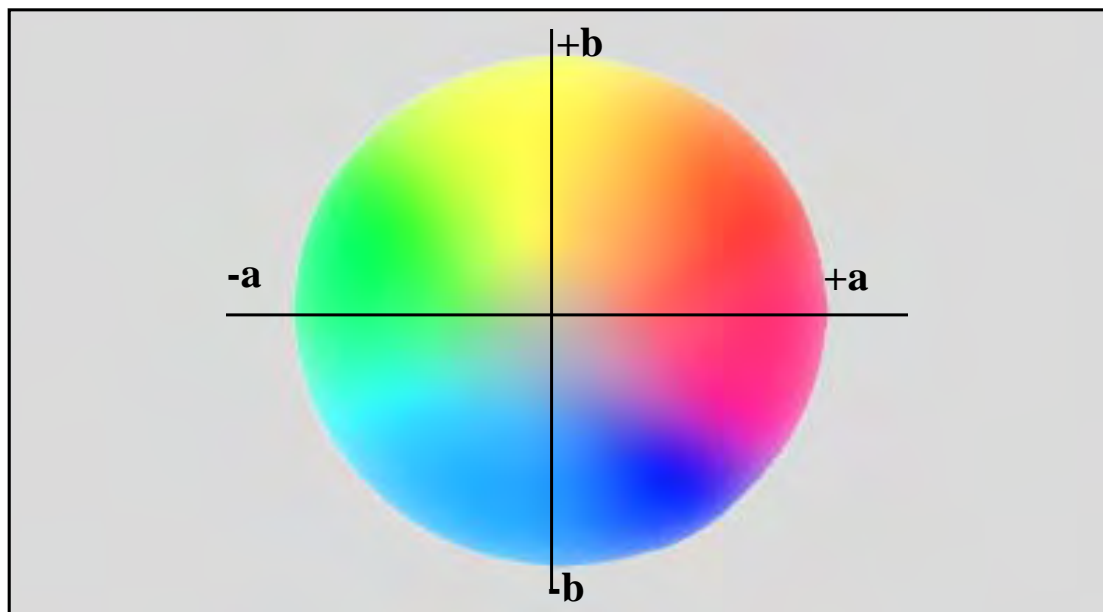

Commission Internationale d'Eclairage (CIE)

Specification of Lab color space 1976

Device independent

Based on the human visual sense



International Color Consortium (ICC)

Specification of ICC profile format 1994

Platform independent

Manufacturer independent



Tools and Methods of Color Management

Color Management Tools...

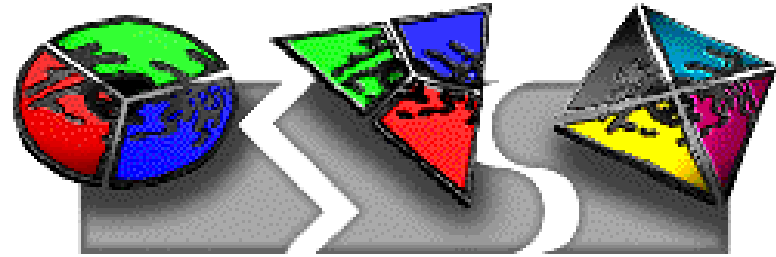

Generation of scanner profiles



Generation of monitor profiles

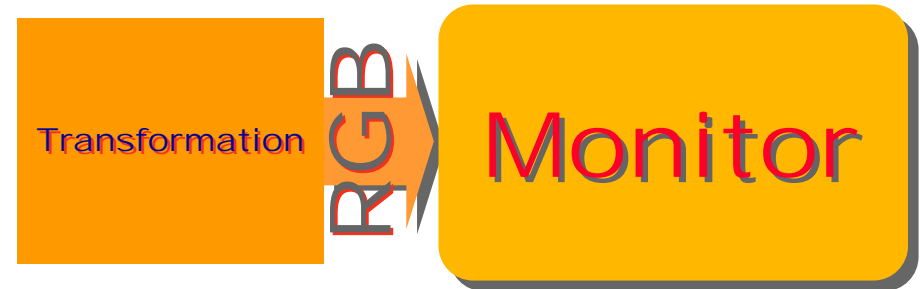

Generation of print profiles



Profiling of input devices: Scanner- and digital camera- profiles

- Generated profile is only valid for a device + setting [Kodak-, Fuji-film].

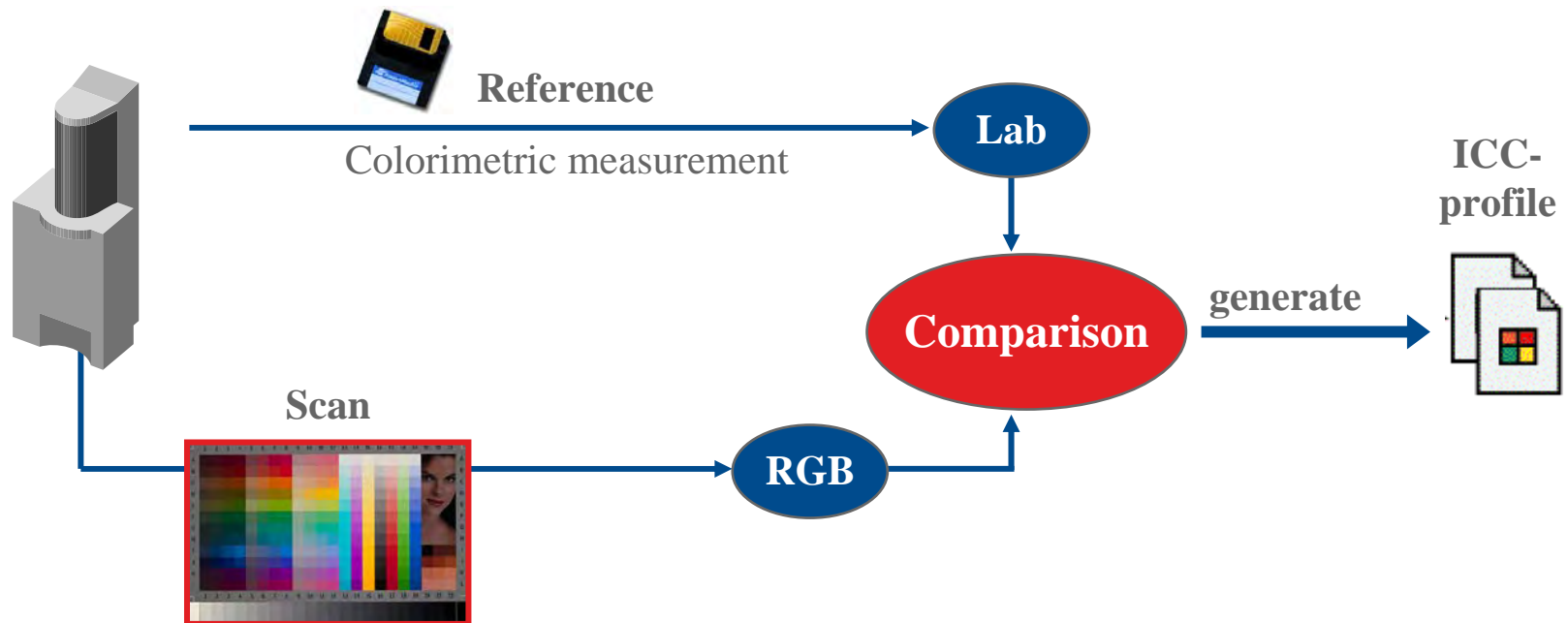

How does it work...

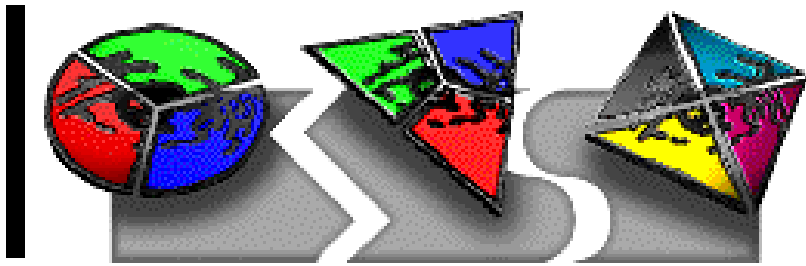

Scanner ICC

Generates ICC-input profiles

For scanners ...

... but also for other input devices
eg. digital cameras



How does it work...

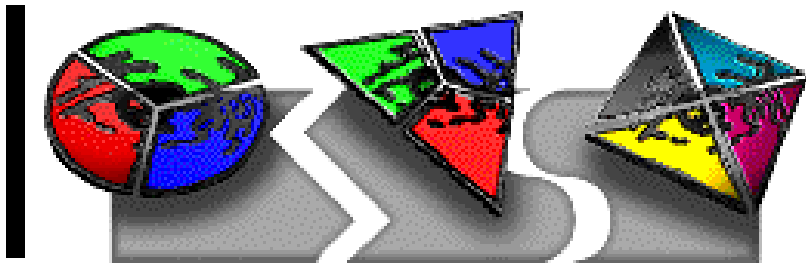

Scanner ICC

- ⑩ **Uses test targets of all main film manufacturers**
- ⑩ **Reflective, transmission**
- ⑩ **IT 8-Originals from Kodak, Fuji and Agfa**
- ⑩ **(Match Targets incl. diskettes with average Color values)**
- ⑩ **Calibration profiles for all purposes**
- ⑩ **More than a Scanner calibration**
- ⑩ *eg. How does my scanner sees the colors of a Kodak transparency?*

How does it work...

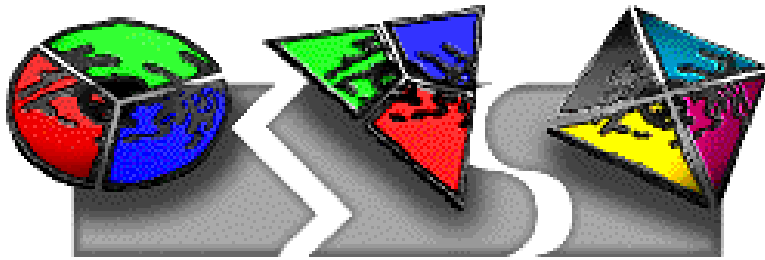

Scanner ICC

Generation of scanner profiles

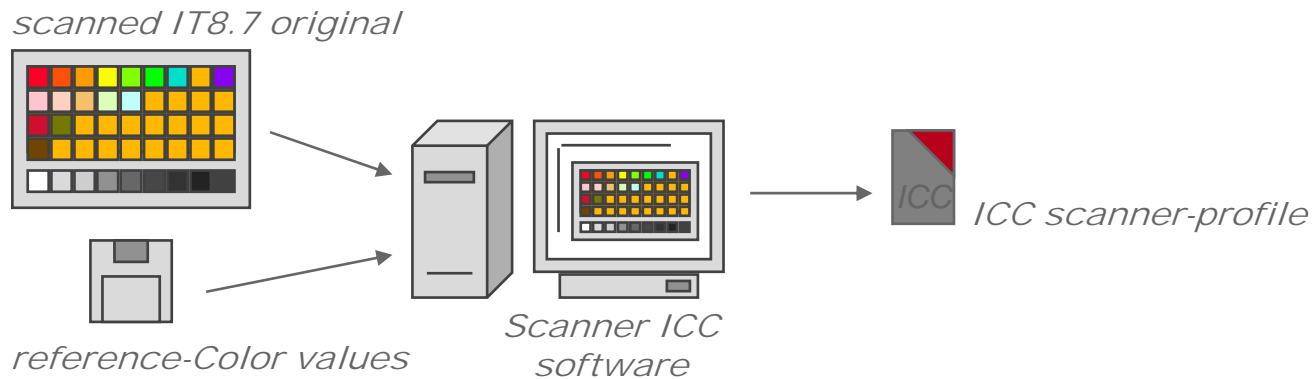

Supported Testcharts

Agfa, Fuji and Kodak materials

transparent/opaque, special materials

Profiling of display devices: Display- resp. monitor - profiles

- Generated profile is only valid for a + setting [brightness/contrast]

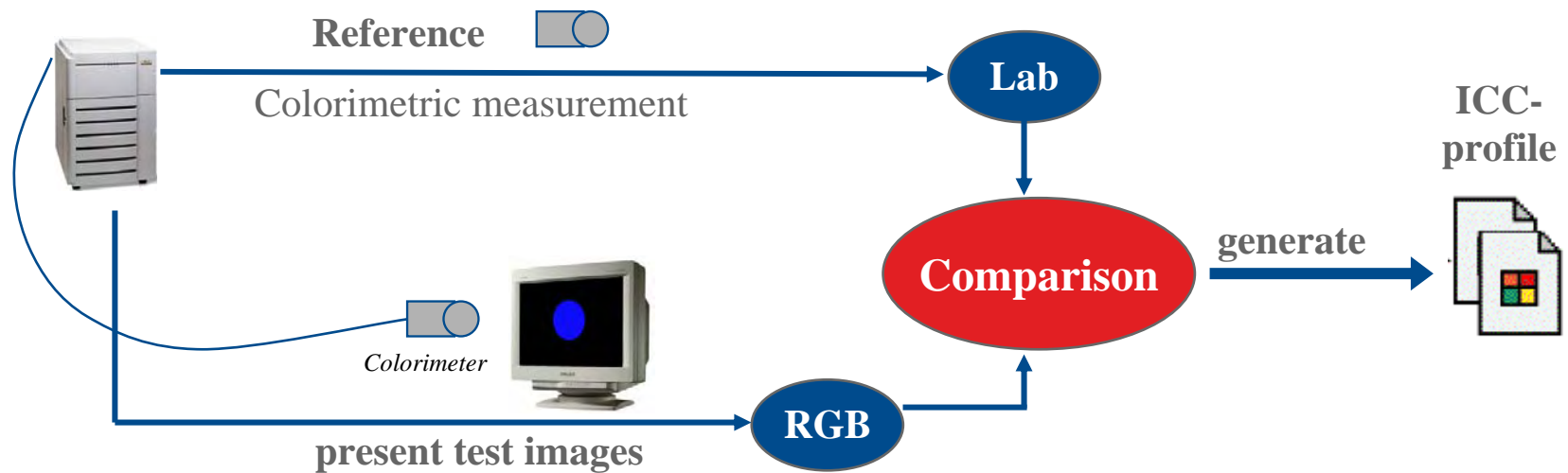

How does it work...

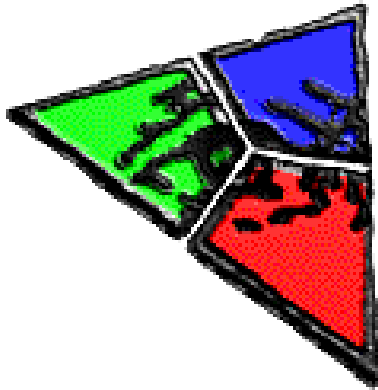

Monitor ICC

Generation of monitor profiles

- Generation of monitor profiles for all Macintosh Color monitor
- Inclusive measuring device
- Gamma curves are not changed

How does it work...

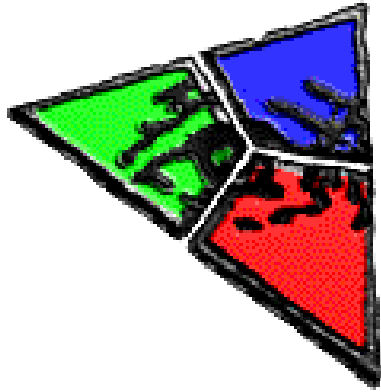

Monitor ICC

Generation of monitor profiles

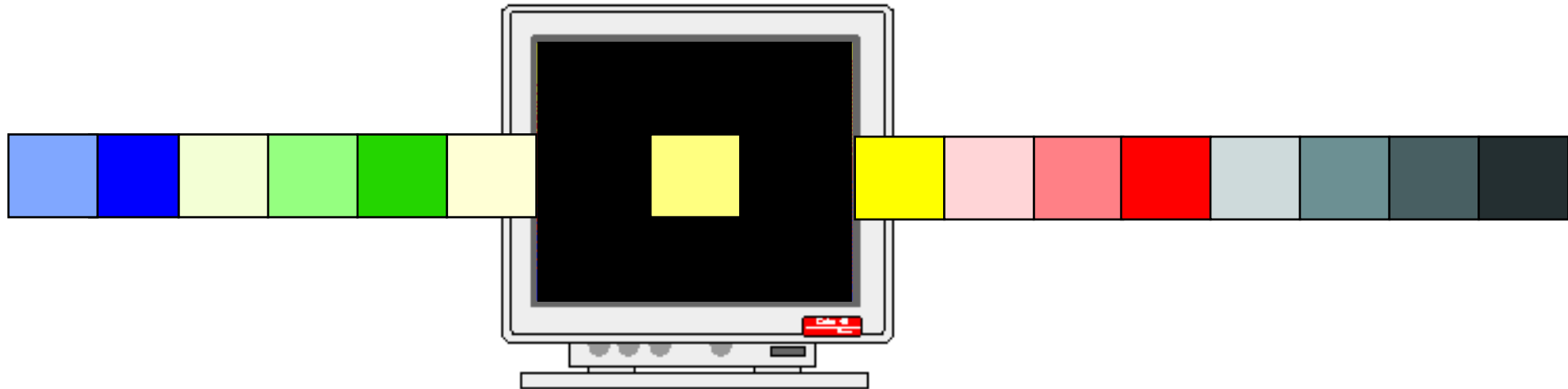

- ⑩ Adjust brightness and contrast
- ⑩ Measure Color targets with measuring device on monitor
- ⑩ Generate profile

Profile generation in a few minutes

How does it work...

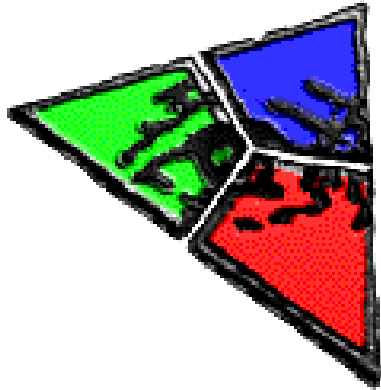

Monitor ICC

Generation of monitor profiles

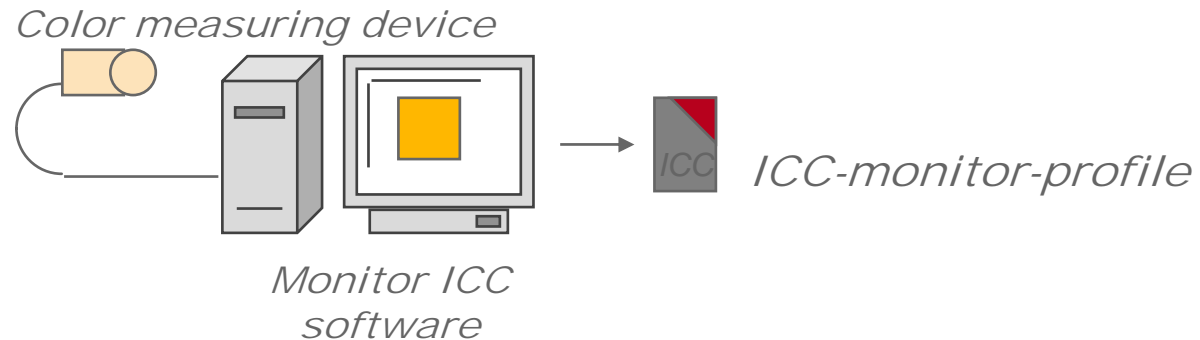

Supported measuring devices

Sequel Chroma 3, X-Rite DTP92, Gretag spectrolino, Colortron....

How does it work...

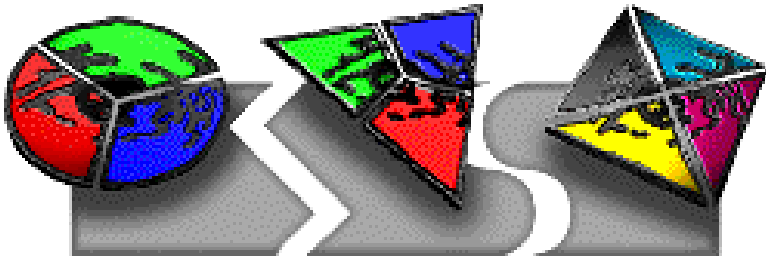

Print ICC

Generation of print profiles

Little theory for the printing (1):

UCR: Under Color Removal (What is Under Color?)

GCR: Gray Component Replacement

Dot Gain: The difference of definition and printing at 45% screening

USM: Unsharp Masking

How does it work...

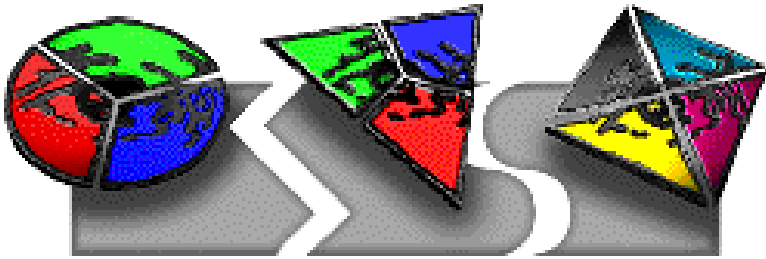

Print ICC

Generation of print profiles

Little theory for the printing (2):

Color Space of print Process

From a 3 dimensional Color Space (Lab, RGB) to a 4 dimensional Color Space (CMYK)

Feedback from the printing process:
Gamut Mapping

Gamut mapping:

Devices have different gamuts

Best - to - fit of different gamuts by transformation of perceivable colors onto actual gamut

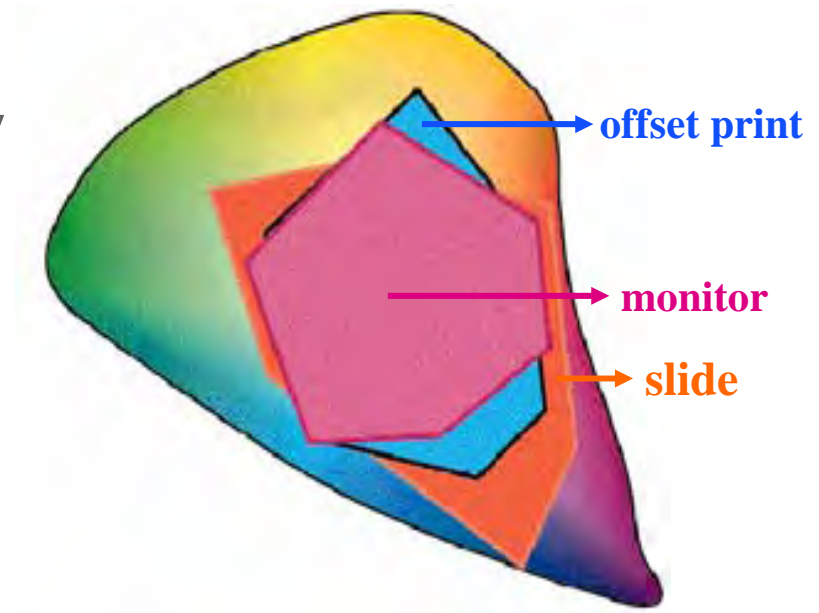
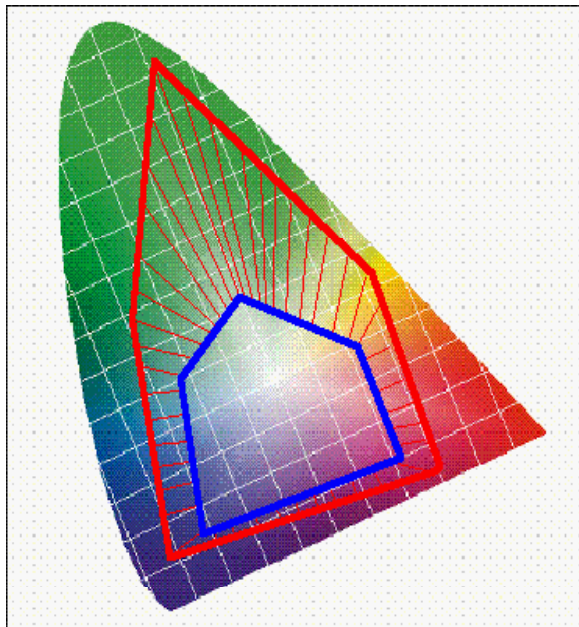

Gamut Mapping

Gamut mapping like a sponge

- strong extern
- weak intern

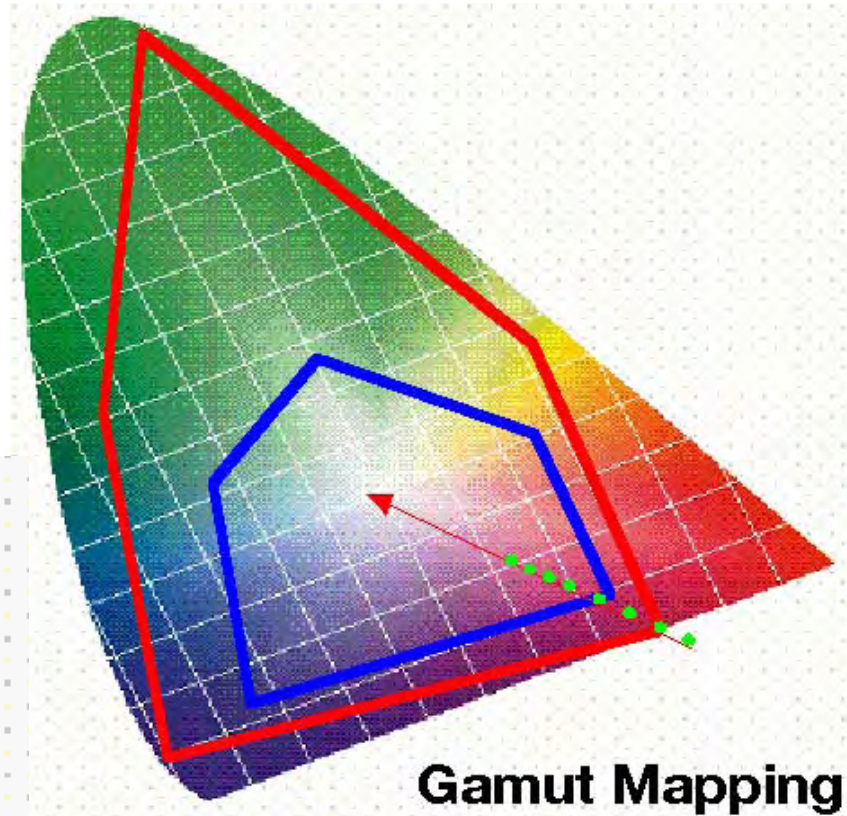
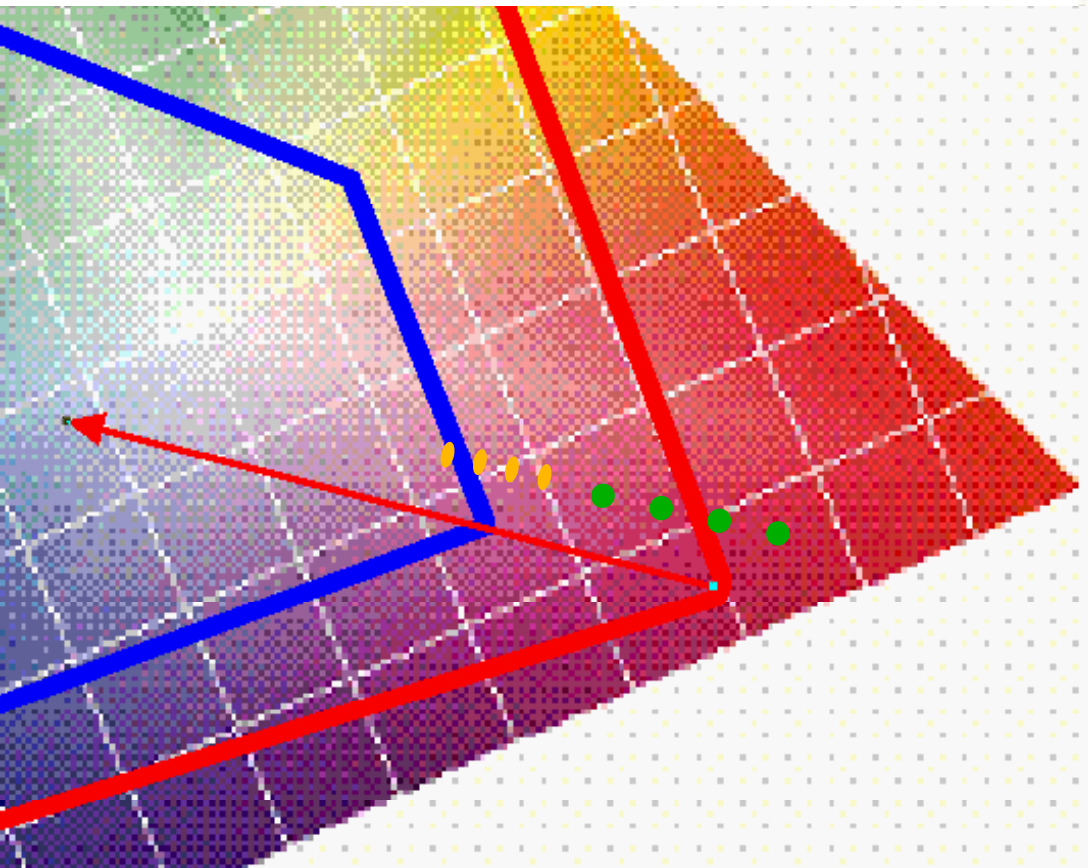

Gamut Mapping

Gamut mapping:

Gamut mapping is usually very complex and highly non-linear

Determines quality of profile and color transformation

- independent evaluation:
 - Different CMM's make only slight differences in the reproduction.
 - The choice of CMM makes far less difference than the choice of profiling SW.

dependent on task context [*normal transformation versus proofing*]

- **controlled by “rendering intents”**

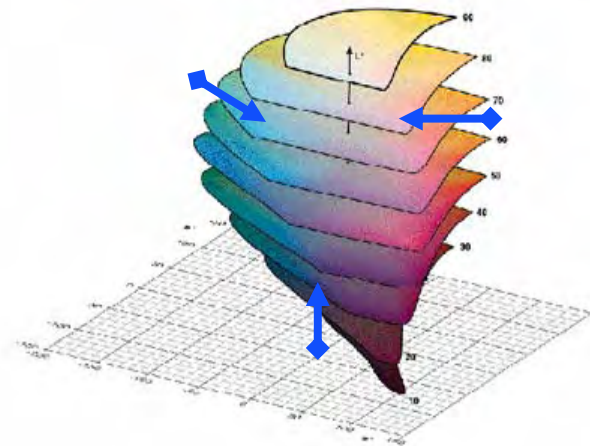

Dependent on color location
because of human perception

Profiling of output devices: Output - resp. printer profiles

Determine color gamut of process

optimize gamut mapping / minimize differences

generated profile is only valid for a device + setting [paper sort, inks]

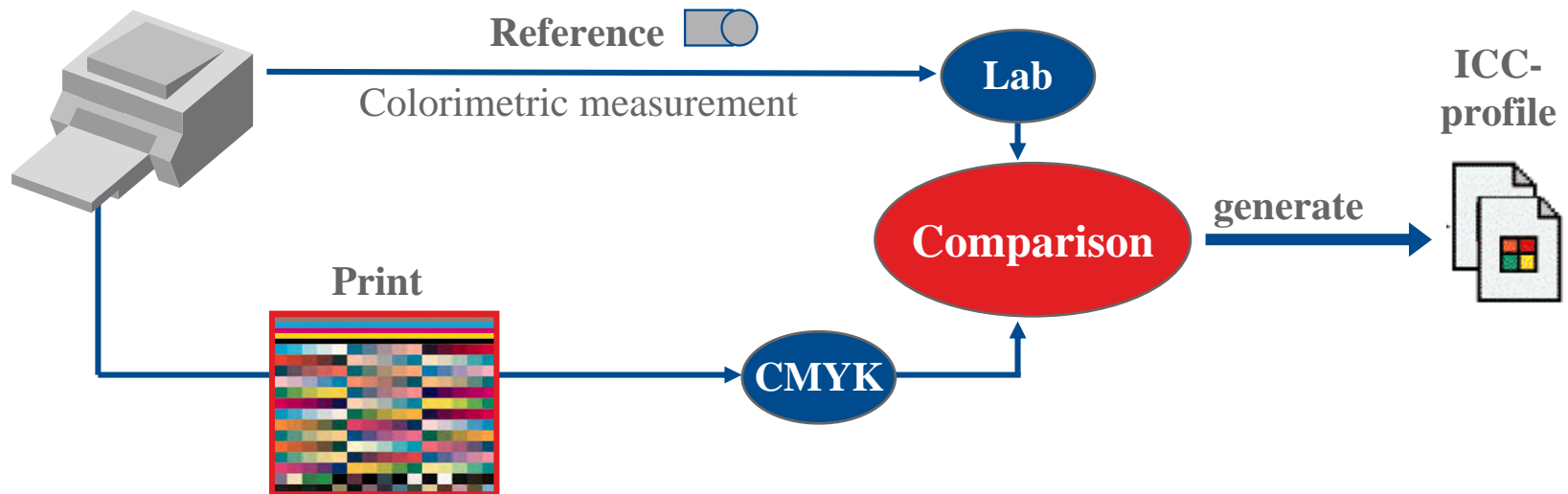

How does it work...

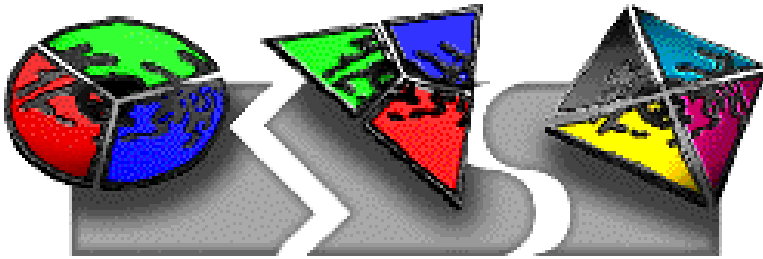

Print ICC

Generation of print profiles

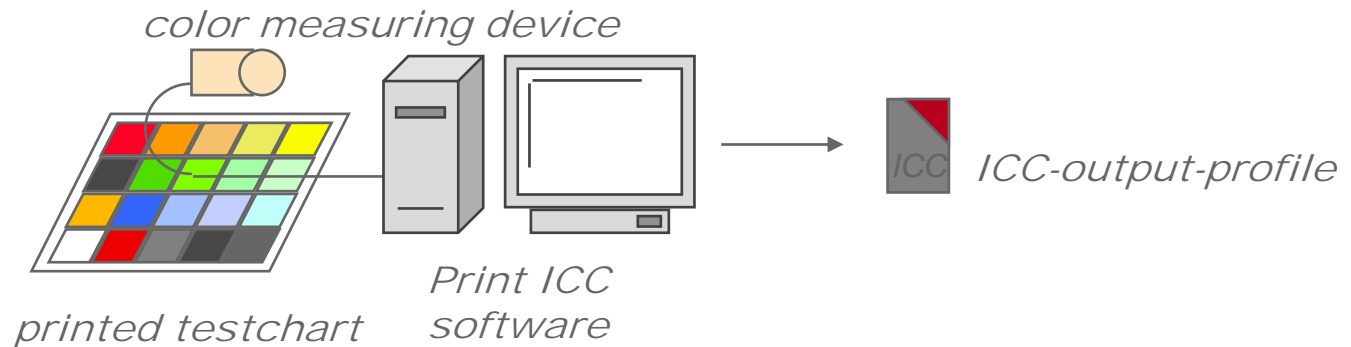

Supported measuring devices

Gretag SPM series, Gretag spectro scan,
X-Rite Digital Swatchbook, Colortron II...

How does it work...

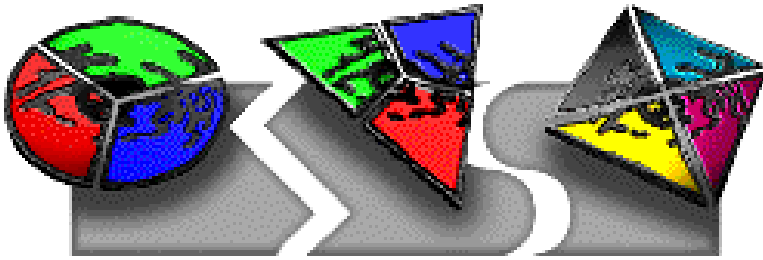

PrintOpen ICC

Generation of print profiles

⑩ offers many setup possibilities:

⑩ Gamut Mapping

⑩ Dot gain

⑩ UCR & GCR

⑩ Gray balance

⑩ etc....

⑩ *For presses and special applications*

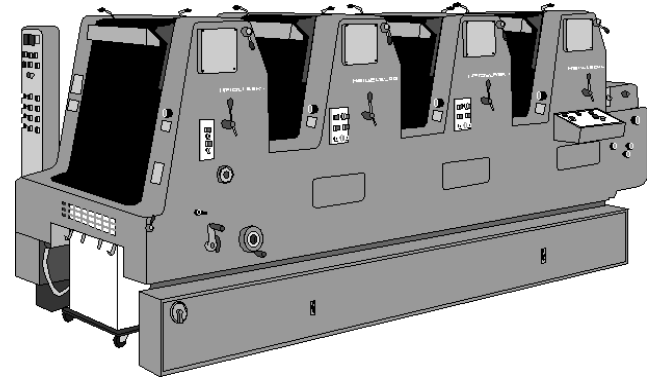

How does it work...

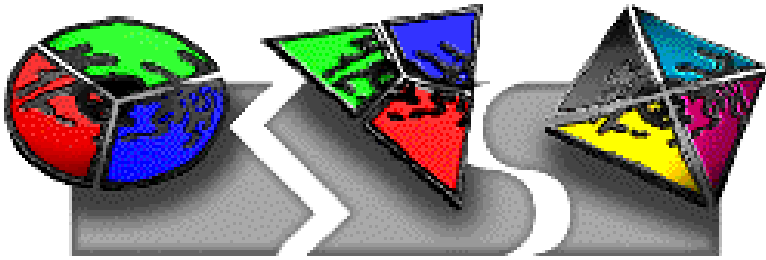

Print ICC

Generation of print profiles

⑩ Profiles for individual print processes

⑩ Special profiles

⑩ ... for newspaper print

⑩ ... for gravure printing

⑩ ... for flexoprint

⑩ ... for silk screen printing

⑩ ... for every specialized print process

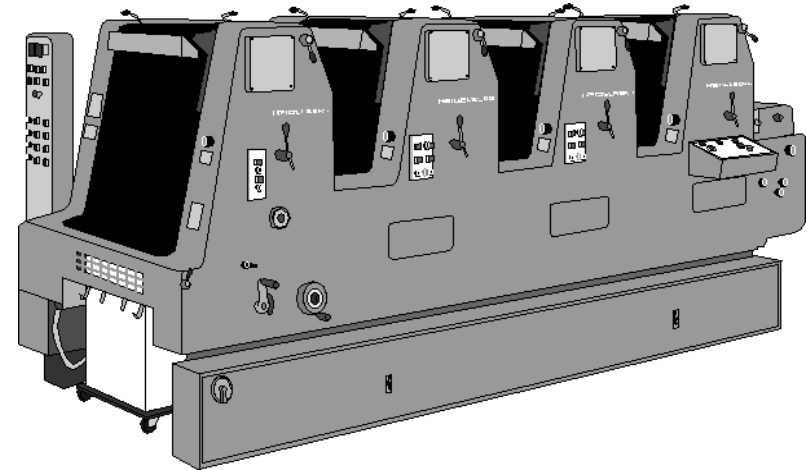

How does it work...

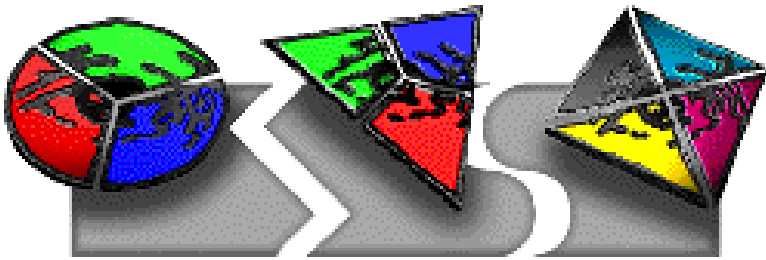

Print ICC

Generation of print profiles

⑩ ICC profile generation:

⑩ Highest quality through outstanding Color know how and experience

⑩ $32 \times 32 \times 32 =$

⑩ 32 768 Reference points

⑩ Works with many manual and automatic spectral photometers



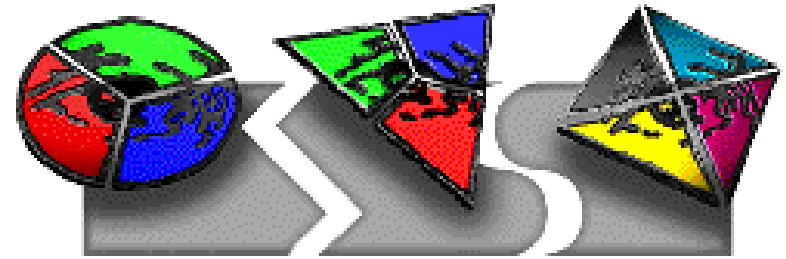

The real world with Color Management

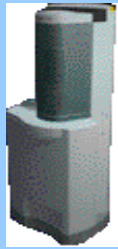

Scanner



Monitor



Proofer

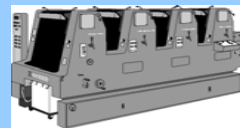

Press



Color Proofing Workflow with Color Management

What is proofing ...

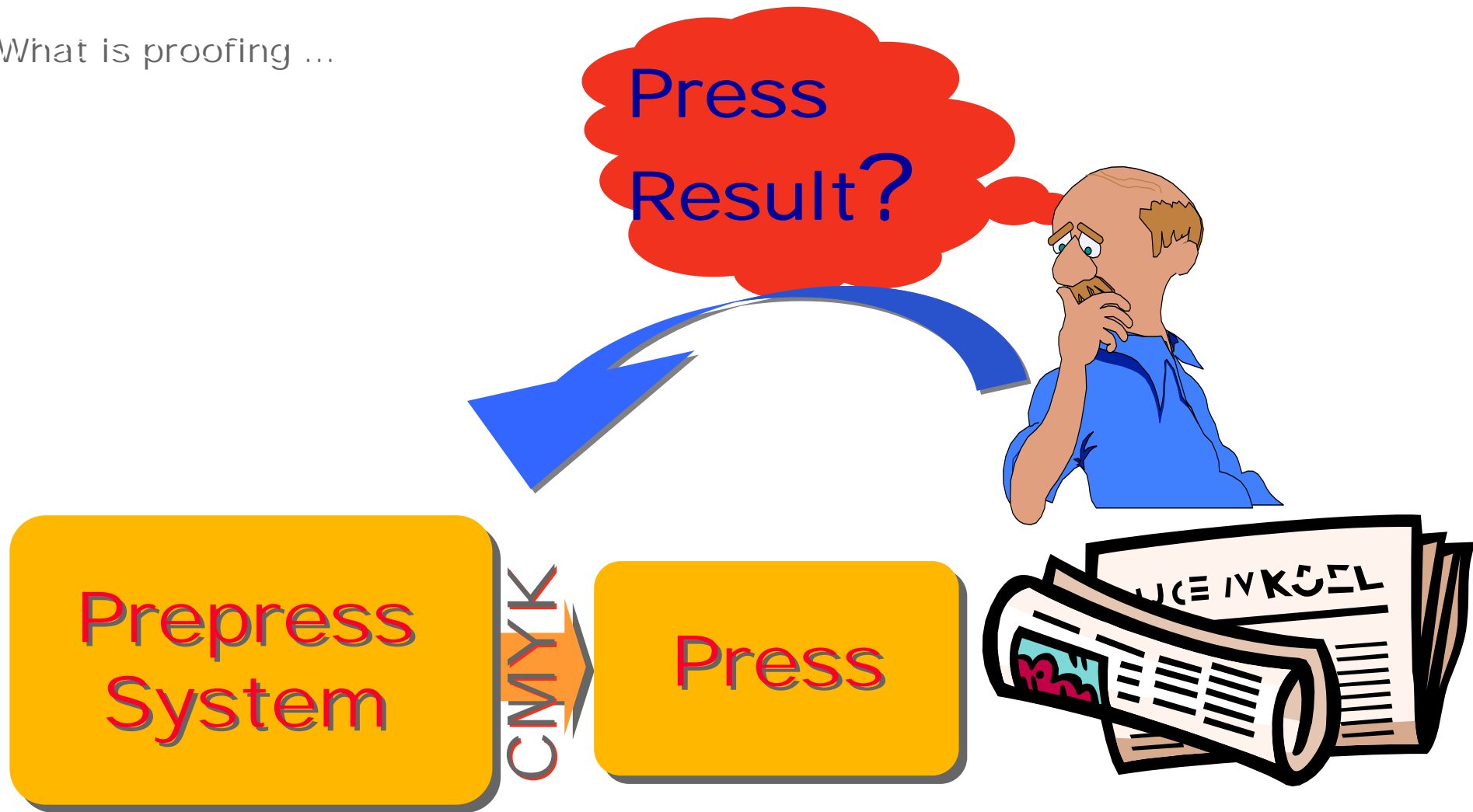

Proof is to see the result of the printing process in ADVANCE.

Conventional Proofing...

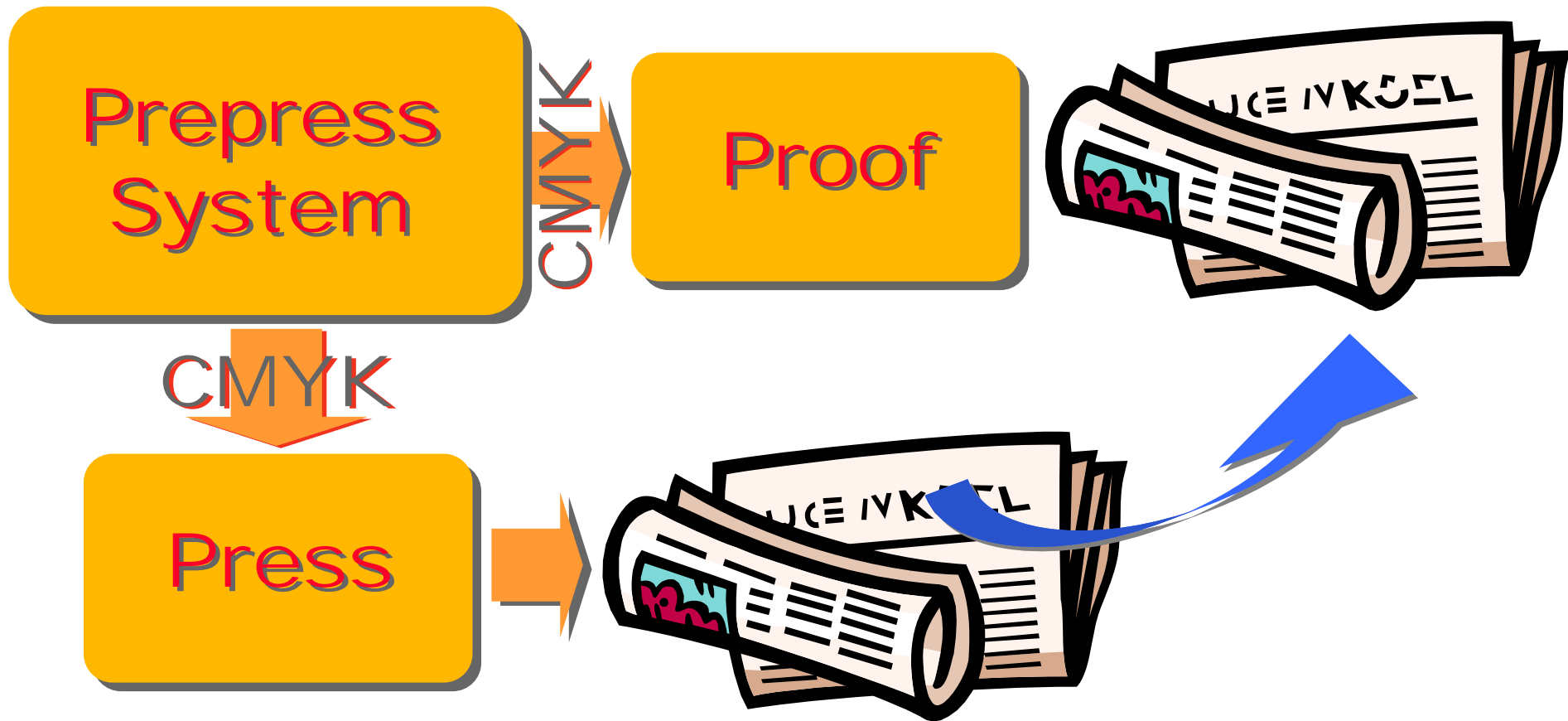

What Proofing Should Be...

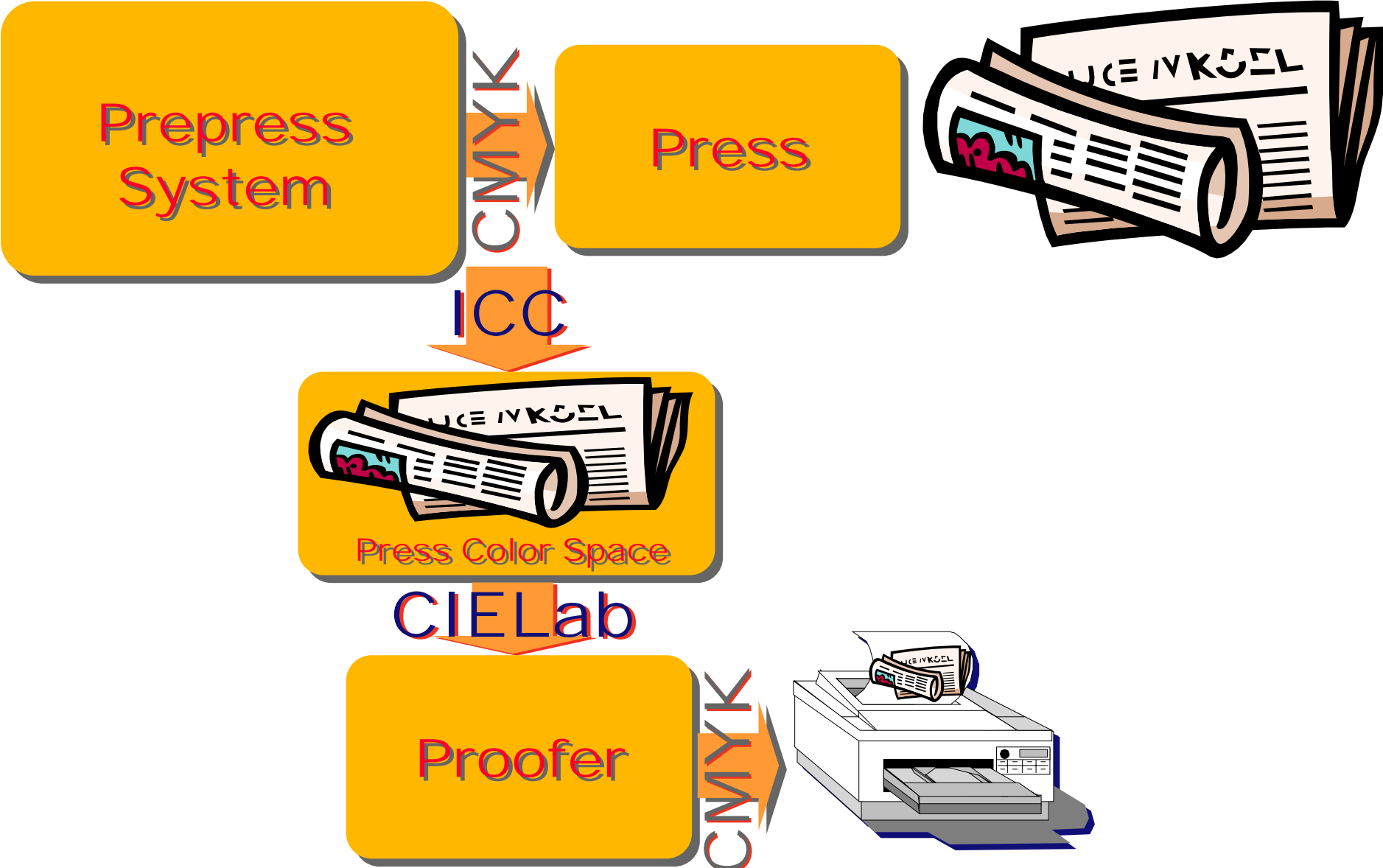

Digital Proofing Workflow...

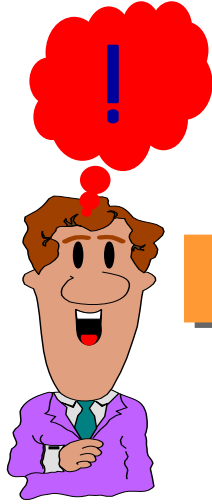

CIE Lab

Press
ICC Profile

CMYK

Press
ICC Profile

CIE Lab

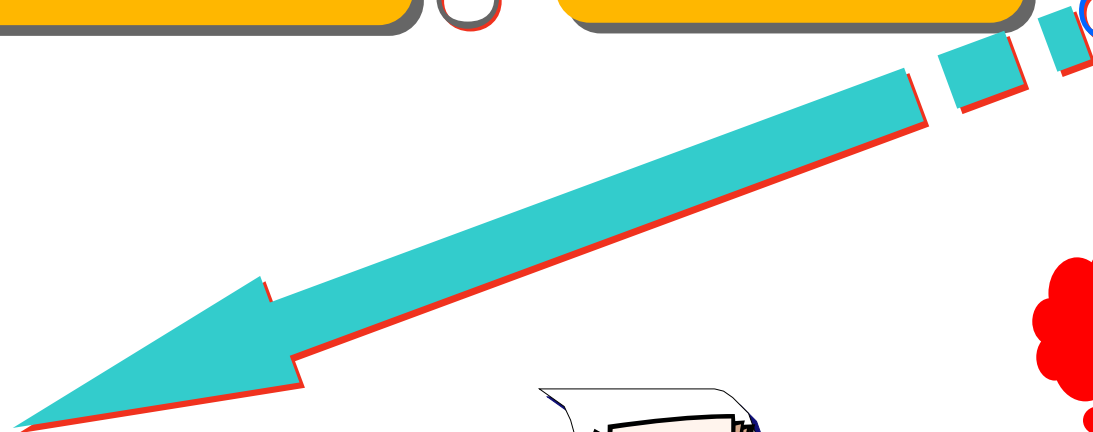

CIE Lab

Proofer
ICC Profile

CMYK

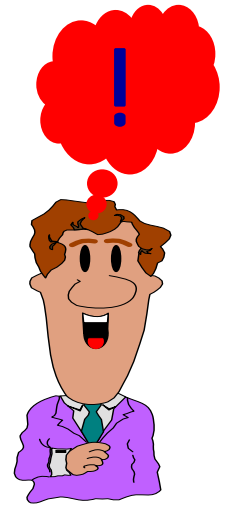
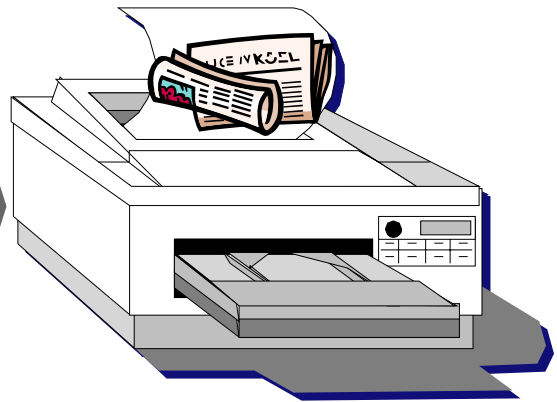

Example for practical CMM use

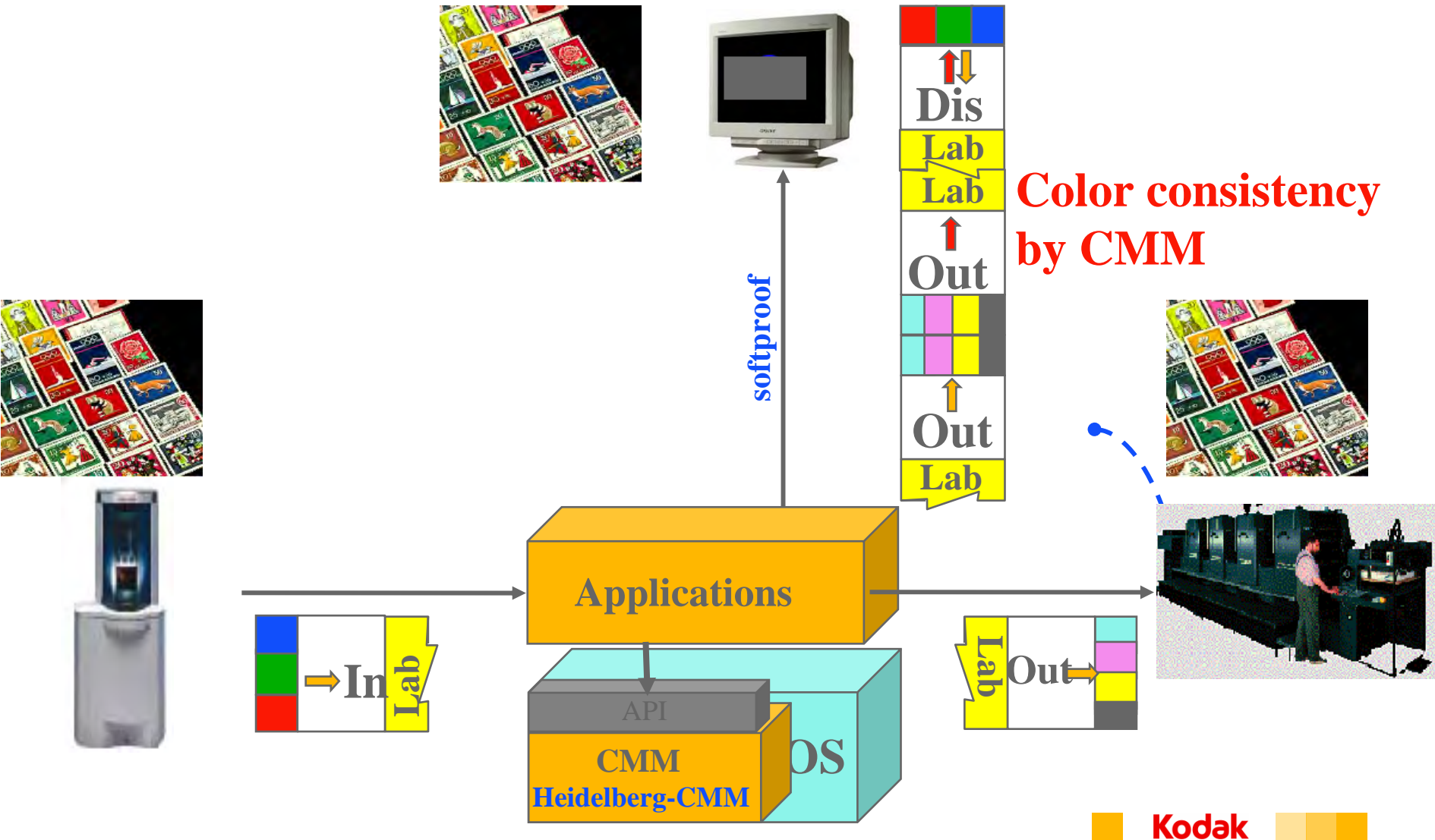

ICC - Profiles:

- Characterisation of devices
 - input devices
 - output devices
 - display devices
- describes the properties of the device in different contexts

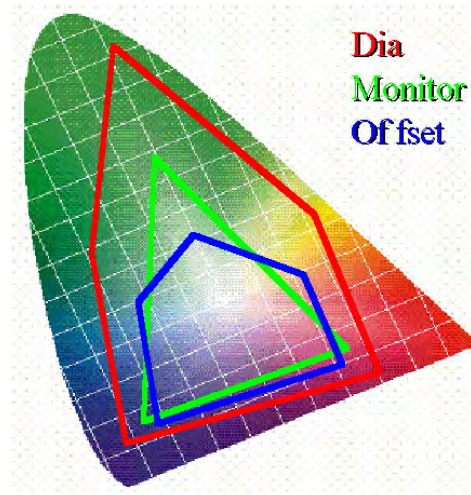

Profile Classes: Class I

Input



profiles

device dependent



CIELab



Display

profiles

CIELab

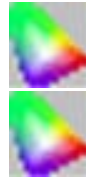

device dependent

CIELab

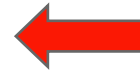

device dependent



Output

profiles

CIELab

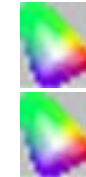

device dependent

CIELab



device dependent



CIELab



device dependent

CIELab

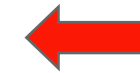

device dependent

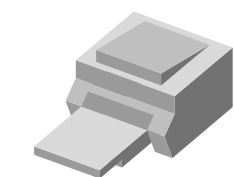

Profile Classes: Class II

Color space conversion profiles

standard colorspace

CIELab



sRGB



CIELab



Device link profiles

device dependent



device dependent

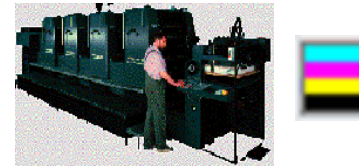
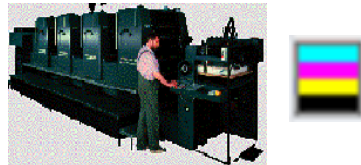
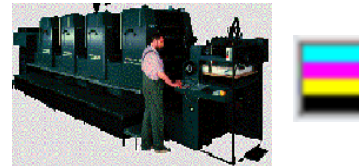

Abstract

CIELab



profiles



CIELab



Named color

CIELab



profiles



indexed colors

Control of gamut mapping by rendering intents

- **perceptual**
- relative
- saturation
- absolute

- 0 **visually optimal**
- 1 conservation of luminance
- 2 conservation of chroma
- 3 no mapping in L

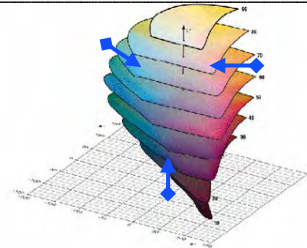
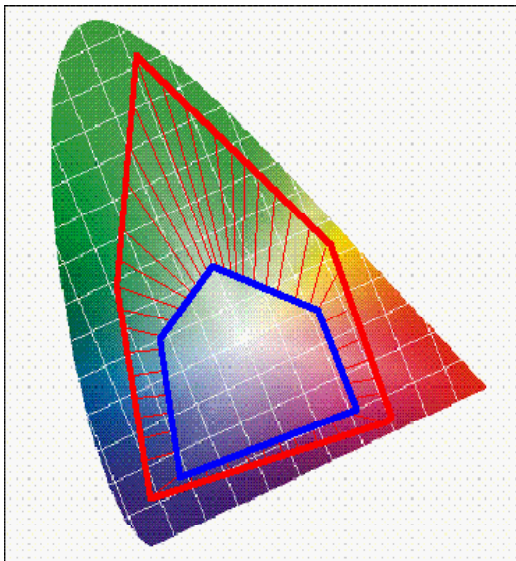

Rendering intents:

Rendering intents powerful, but dangerous tool

False selected rendering intents - **bad results**

Rendering Intents by Proofing

Example for paperwhite simulation on / off

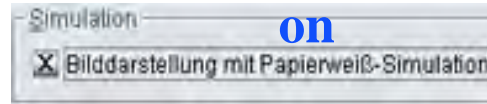

EuroOffset 375 K85



Newspaper IFRA GCR70

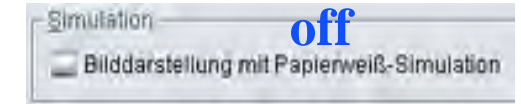

Newspaper IFRA GCR70



Inverse gamut mapping: try to get the original gamut back

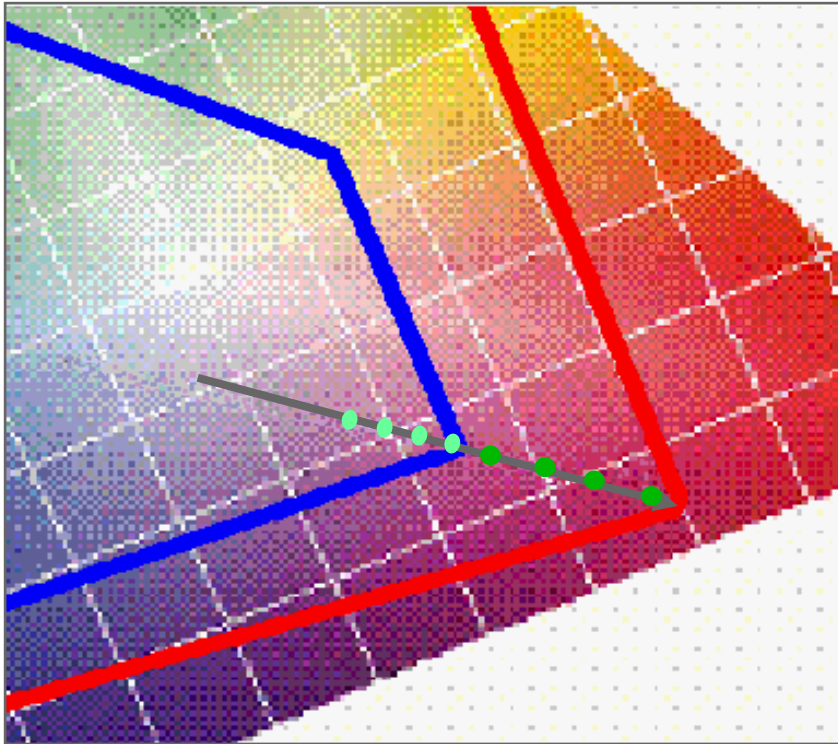

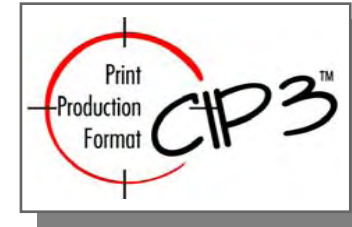

CIP3: What is CIP3?

- CIP3 stands for "Cooperation for Integration of Prepress, Press and Postpress"
- PPF (Print Production Format): able to hold the following information:
 - Job and administrative data (in the admin block)
 - Low-resolution bitmaps of press sheets
 - Transfer curves
 - Register marks
 - Color and density measurement patches
 - Cutting and folding information

CIP3 Advantages...



- Improved quality monitoring (fully automatic)
- Faster production cycles (due to shorter makeready times and reduced operator error)
- Lower costs (less waste paper, shorter makeready times, no plate scanner needed)
- Simpler plate handling (because they don't need to be scanned)
- Automation, "streamlined production" (the data is available in one file for all stages from prepress to finishing)
- Future-oriented: open for future developments

This is the workflow for Process calibration

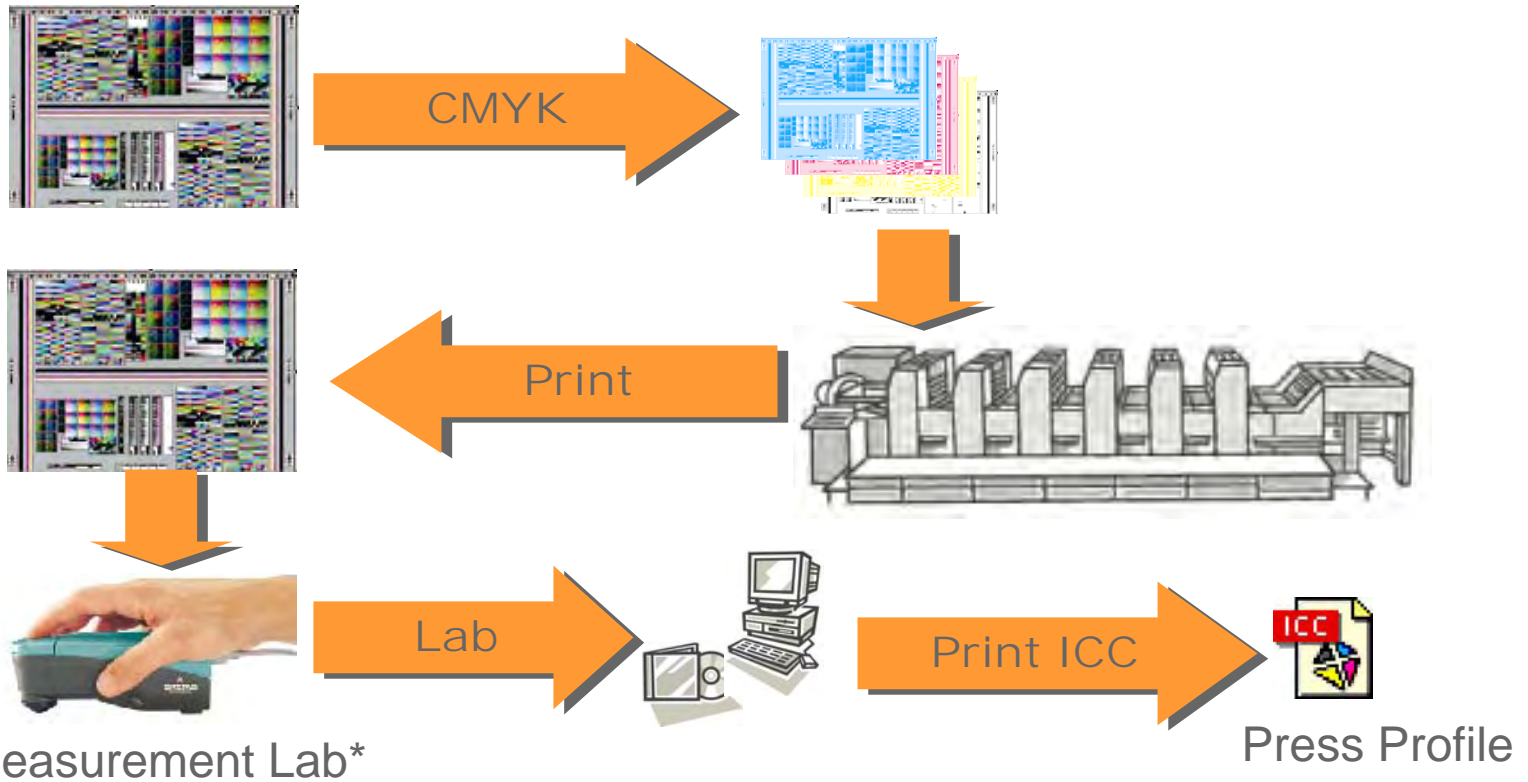

Method and Tools to control the Quality...

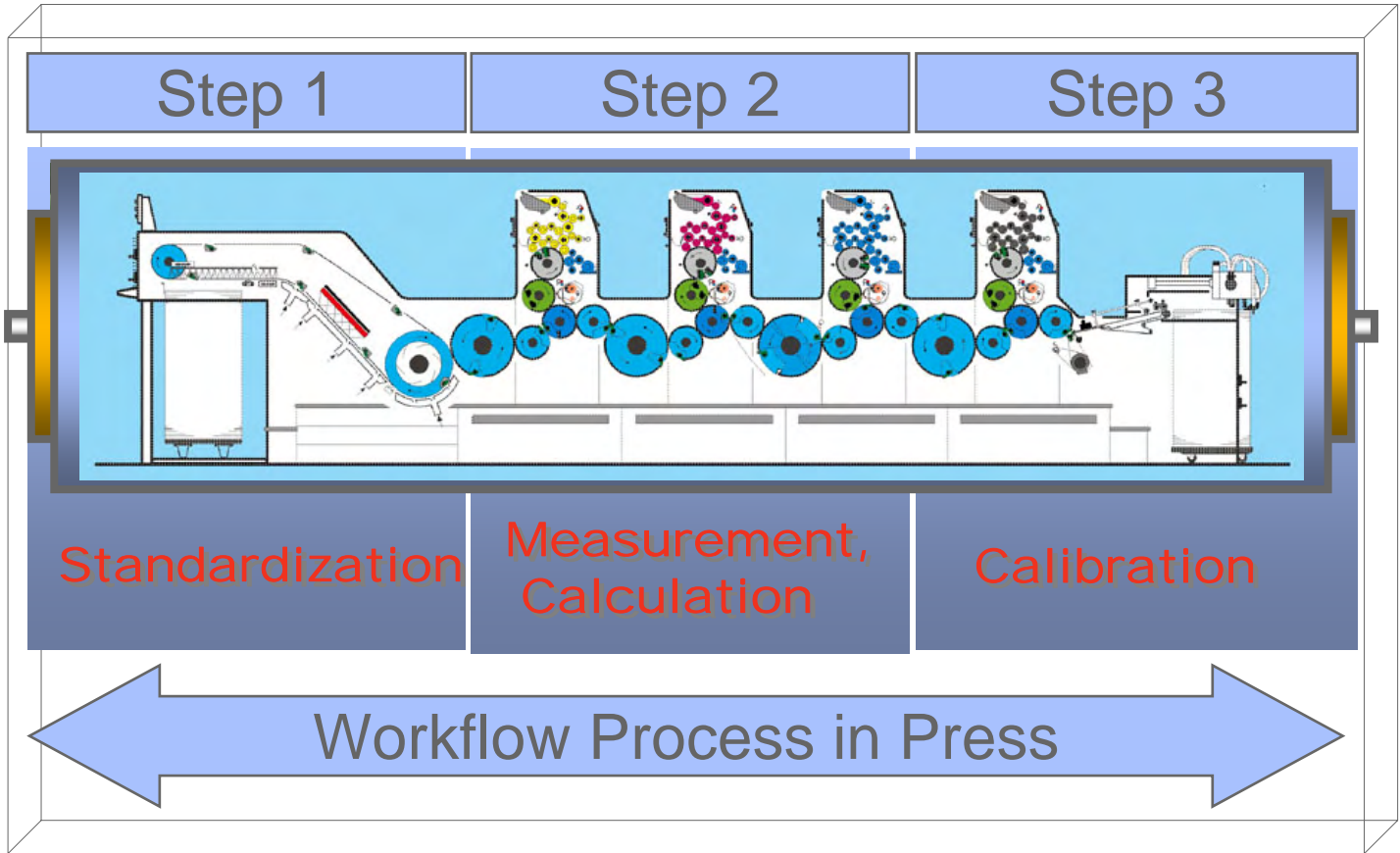

Kodak